

**ORIGINAL HEIDELBERG
CYLINDER $22\frac{1}{2} \times 30\frac{1}{4}$ " / $22\frac{1}{2} \times 32\frac{1}{4}$ "**

OPERATION MANUAL



**HEIDELBERGER DRUCKMASCHINEN
AKTIENGESELLSCHAFT**

SALES AND SERVICE THROUGHOUT THE WORLD

THIS BOOK SHOULD BE KEPT IN THE MACHINE ROOM

The operation of the Original Heidelberg Cylinder $22\frac{1}{2} \times 30\frac{1}{4}$ " and $22\frac{1}{2} \times 32\frac{1}{4}$ " is very simple. A proof may be seen in the fact that by the end of 1967 approximately 45 000 Original Heidelberg Cylinders had been installed all over the world and enthusiastically received.

The purpose of this instruction manual is to enable printers to obtain the maximum advantage from the machine. We hope that it will not only ensure thorough maintenance of the machine but will promote a better understanding of progressive methods in preparation of the forme and make-ready, the use of inks and the care of rollers.

By following our advice, tested and proved the world over, the printer will obtain the maximum efficiency from his Original Heidelberg Cylinder.

**HEIDELBERGER DRUCKMASCHINEN
AKTIENGESELLSCHAFT**

CONTENTS

Table of most important adjustments for various stock	9	Cleaning the air filter in the suction and the air pump	36
Specifications for the Original Heidelberg Cylinder 22½ x 30¼" / 22½ x 32¼"	10	Cleaning the filter of the air pump for the spraying device	37
Floor plan	11	Cleaning the main pinion, gear racks and crankshaft area	37
Oil drip pan	12		
 The design		 Maintenance at longer intervals	
Original Heidelberg Cylinder	14	Readjustment of flywheel brake	40
Reduction to the minimum of make-ready time	17	Exchange of V-belts	41
Cutting down unproductive time	18	Cleaning the suction and blast air pump for feeder	42
 Printing in general		 Operating the machine	
Correct forme alignment	22	Control of the machine	44
Block justification	22	Electrical control equipment	44
Mounting of blocks	23	Operating electric controller	44
Wood mounts	23	Forme and roller guard	45
Lead or iron mounts	23	Single lever control for Stop-Run-Paper-Impression	45
Light metal mounts	23	Stopping the machine	47
Honeycomb base	23	Two step pulley drive	48
Slur	25	Turning the machine by hand	49
Slur — ink too thin	25	Treatment of rubber rollers	49
Slur — ink too tacky	25	Treatment of plastic rollers	51
Slur — caused by forme rollers	25	Inking system	52
Slur — caused by badly mounted blocks	26	When does the printer use 2, 3 or 4 forme rollers?	53
Slur — caused by high or low blocks	26	Inserting rollers in the machine	55
Remedies	28	Inserting the forme rollers	55
Pre-make-ready of forme	29	Taking out of the forme rollers	56
Inking	29	Taking out of the distributor rollers	56
		Adjustment of the vibrator	56
 Maintenance		Adjusting the distributor rollers	57
Running-in the machine	32	Adjusting the forme rollers	58
Lubrication of the machine	32	Disengaging rollers	60
Daily, weekly, and semi-annual oiling	32	Regulating the knife and ink strip	61
Oil lubrication	32	Engaging and disengaging ink supply	62
Grease lubrication	33	Regulating the reciprocating rollers	63
Central lubrication	34	Operating the roller washing device	64
Gear box oil bath	35	Cleaning the duct and the ductor blade	68
Cleaning the machine	35	Cleaning the splash guard	68

Positioning the forme	69	ing boxes on the Original Heidelberg Cylinder	115
Locking the forme on the bed	70	Numbering with plunger operated numbering	
Selecting cylinder packing	72	boxes	116
Adjusting cylinder pressure on bearers	73	Device for adjusting formes	116
Clamping the packing	74	Adjusting formes to be locked between the	
Make-ready	76	bearers	120
Loading the feed table	77	Preloading device for feeder	122
Regulation of suction	78	Device for continuous delivery	125
Regulation of sucker bar tilt	78	Die-cutting, scoring, creasing and slitting on	
Sheet separation	79	the Original Heidelberg Cylinder	126
Regulating rate of lift of the feed table	80	Device for carbon printing	127
Use of tissue slides	80	Device for eliminating static electricity	128
Use of rubber suckers	81	Perforating and cutting on the Original	
Use of rubber rollers on the feed control bar	82	Heidelberg Cylinder	129
Use of tripping springs	83	Device for printing onion skin	131
Setting the side lays	84		
Adjusting the cover plate	84	Difficulties and remedies	
Micrometer adjustment of side-lay	85	Paper	133
Adjustment of front lays	85	Causes of bad sheet separation and pick up	
Use of smoothers	86	of two sheets on the feed pile	134
Use of sheet brakes	86	Sheet is not picked up	135
Adjusting the swinging grippers	87	Feed table grippers do not catch the sheet or	
Adjusting sheet calipers on the feed board	87	do not catch it correctly	135
Operation of automatic cut-out	88	Troubles on the feed table and at the side lay	136
Cylinder brush adjustment	89	Sheet is not registered correctly at the side	
Fitting new brush	90	lay — bad registering	136
Cleaning the brush	90	Troubles with transport of sheet on the feed	
Adjusting the delivery table	91	board	136
Adjustments on chain delivery system	94	Slur	137
Air blast for the sheet delivery	96	Working up in the forme	137
Removing the wheeled delivery table	97	Bad inking	137
Powder or liquid spraying	97	The printed sheet shows hairline smears	138
Liquid spraying apparatus	98	The sheet shows broad smears	138
Directing the spray	100	The print is scratched on the rear side of the	
Cleaning the spraying apparatus	100	sheet	138
Powder apparatus	102	Troubles at the delivery	138
Cleaning the powder apparatus	104	Sheet is taken back by the delivery carriage	138
Other points to be observed when using the		Machine is not cut-out automatically if no	
spraying apparatus	106	sheet is fed	138
The impression counter	107	Instruction for eliminating troubles with the	
Tool rack	107	spraying apparatus	139
Forme and delivery lighting	107	Instructions for overcoming troubles with the	
		powder spraying equipment	140
Extra equipment		Original Heidelberg Cylinder 22½ x 32¼"	
Device for printing two up	110	Cutter and Creaser	142
Locking forme when printing two-up	112	To the machine — minder operating the	
Device for printing between bearers	113	22½ x 30¼" / 22½ x 32¼" Original	
Device for hot embossing	114	Heidelberg Cylinder	146
Numbering with centrally controlled number-		The Heidelberg manufacturing programme	147

INDEX

A

Accessories 108
Air blast — delivery 20, 96
Air blast — feeder 79
Air filters 36, 37, 82
Air pump 36, 42
Air suction regulation 78
Anti-Offset spray 97, 106
Automatic cut-out 88, 89, 138
Automatic impression lever control 46

B

Ball bearings — lubrication 32, 33
Ball handles 18
Base guards 37
Brake — adjustment 40, 41
Brush — adjustment 89, 90

C

Carbon printing 127
Cardboard feeding 9, 80, 81, 83, 87, 88
Center divider — delivery 111
Center divider — feeder 110
Center side lay 111
Central lubrication 34
Chain delivery 94, 95
Chases 10, 70, 71, 112
Cleaning of the machine 35, 36
Cleaning of the main pinion gear rack 37, 38
Climatic conditions 133
Composition of the packing 72
Composition of the rollers 52, 53, 54
Continuous delivery 20, 97, 125, 126
Control box 44
Control lever 18, 45, 46
Corn starch 30
Creasing 126, 127
Cutter and Creaser 142

Cylinder 17, 73
Cylinder brush 89, 90
Cylinder sheet guide 86

D

Delivering dividing plate 111
Delivery difficulties 139
Delivery lighting 44, 107
Delivery separation boards 106
Delivery sheet stops 91, 92, 93, 94
Delivery star-wheels 94, 95, 138
Delivery table 91, 92, 97
Delivery table control 91
Die cutting 126
Die cutting plates 127
Distributor rollers 57
Drip pan 12
Drive 44, 48
Ductor roller 68

E

Electrical control box 44
Electrical equipment 44
Electricity — static 128, 133, 134
Embossing 114

F

Feed lift 80
Feed suckers 81
Feed table 77, 122
Feed table height 77
Feed trouble 133
Feeder preloading device 122, 145
Feeding small sizes 110
Filters 36, 37, 82
Floor plan 11
Flywheel guard 48
Forme and roller guards 45

Forme gauging 22
Forme lighting 107
Forme locking 70
Forme positioner 116
Forme positioning and alignment 22, 69, 70
Forme rollers 19, 30, 52
Forme roller adjustment 58, 59, 60
Forme roller combinations 53, 54
Forme roller lubrication 33
Forme roller removal and replacement 55, 56
Front lays 85, 136
Front lay adjustment 85, 87
Fuses 44

G

Gauge for packing thickness 22, 23
Gauge for rollers 59
Gauge for type height 22
Gear box lubrication 35
Grease gun 32, 33
Grease nipples 33
Gripper margin 10, 69, 85
Guard between cylinder and inking mechanism 68
Guards for base 36
Guards for delivery 38
Guard for formes and rollers 45

H

Height control bar — feeder 82
Height of plates 22, 23, 26
Honeycomb Base 23, 24
Hot embossing 114
Humidity in the pressroom 133, 134, 137

I

Imposing board 70, 116, 121
Imposing surface (device) 19, 116
Impression cylinder 17, 22, 26, 46, 74
Ink dryers 30
Ink film 53, 54

Ink flow 61, 62
Ink duct 61
Ink duct blade 68
Ink duct heating 128
Ink mixing 30
Ink roller reciprocation 63
Ink slur 25
Ink supply 61, 62
Inking 29, 30, 137
Inking system 19, 52

L

Locking forme between bearers 113, 120, 121
Locking forme on bed 70
Locking forme for two-up 112
Lubrication 32, 33, 34, 35

M

Main control switch 44
Main pinion gear and racks 37
Maintenance 31
Makeready 76
Makeready, die-cutting 127
Makeready time 76
Metal mounts 23
Micrometer gauge 22
Microscope 26
Mixing of inks 30
Motor 44, 48
Moving sheet Guides 93

N

Numbering and numbering boxes 115, 116

O

Oil dip-stick 35
Oil gun 32, 33
Oil lever — central lubrication 32, 34

Oil lubrication 32, 33, 34
Oil nipples 32, 33
Oil reservoir — central lubrication 34
Onion skin paper 9, 79, 80, 131

P

Packing clamp 74, 75
Packing draw bar 75
Packing pins 75
Packing thickness 10, 22, 27, 72
Paper dust 36, 37, 82
Paper margin 10, 69, 85
Paper sizes 10
Paper storage 133, 135, 138
Perforating 129
Plate mounting 23, 24, 26
Plastic rollers 29, 30, 51, 53, 67
Position of side lays 84, 85, 110
Positioning of forme 69, 70
Positioning for two-up printing 111
Positioning of forme between bearers 120, 121
Powder spraying apparatus 102
Pre-loading device for feeder 122, 145
Pre-makeready of forme 29
Press blanket 72, 75, 76
Printing between bearers 113, 120, 121
Printing of small sizes 110
Printing oil 30
Printing paste 25, 30
Printing thin stocks 9, 80, 81, 96
Printing troubles 25
Printing two-up 110
Problems and remedies 132
Pump 36, 42
Pump maintenance and lubrication 36, 42

Q

Quick stop 47, 48

R

Reciprocation 63
Register 136

Regulation of ink strip 61
Regulation of speed 32, 44, 48
Rice flour 30, 51
Roller cleaners 49, 50, 51
Roller combinations 52, 53, 54
Roller gauge 58, 59
Roller guards 45
Roller rack 50
Roller specifications 52, 53, 54
Roller washing 64, 65, 66, 67
Rollo-paste 49
Rubber rollers 29, 49, 50
Rubber suckers 81
Running-in the machine 32

S

Sand paper sleeves 95
Scoring 126, 127, 131
Semi-annual lubrication 32
Sheet-brakes 86
Sheet calipers 87, 88
Sheet counter 107
Sheet separation 9, 79
Sheet smoother 86, 136
Sheet travel on feed board 19, 136
Side lays 84, 85, 110
Side standards 123
Single lever control 45, 46
Size ranges 10
Skeleton chases 10
Slitting 126, 127
Sludge trough 66
Slurs 25
Smears on printed sheet 138
Special chases 10, 115
Specifications 10
Speed control 44, 48
Splash guard 68
Starting the machine 45, 46
Steel plate for die-cutting formes 127
Static electricity 128, 133
Static eliminator 128

Star wheels 94, 95
Stopping the machine 47, 88, 89, 138
Spray trouble — correcting chart 140, 141
Suckers 80, 81
Sucker bar tilt 78
Suction regulation 78
Swinging gripper adjustment 87

T

Tissue slides 80
Tools 107
Transparent plastic sheet 117
Turning machine by hand 49

Two-sided adhesive 23, 26
Two-up printing 110

V

V-belts — replacement 41
Variable speed control 44, 48

W

Washup blade 64, 66
Washup solution 49, 50, 51, 67
Washup sludge trough 64, 66
Wiring diagram 44
Work-up causes 137

Table of most important adjustments for various stock

This table can only give the approximate adjustment. Maximum production speed on each run depends upon paper, size, and ink. The experienced printer will, therefore, make minor adjustments as the run proceeds until he has obtained the highest possible running speed.

Adjustments	Air-Mail and Thin Paper	Medium-Weight Bond	Cardboard
Distance of Feed Pile from Suckers	Top sheet approx. $\frac{1}{2}$ " (12 mm) from suckers	Top sheet approx. $\frac{1}{4}$ " (6 mm) from suckers	Top sheet directly under suckers
Sucker Bar Tilt	Usually use plenty of tilt, but there are thin papers which can be run better without tilt	Tilt indicator in centre position	No tilt. Indicator on "Cardboard"
Paper Feed	Paper feed indicator on or near "Thin Paper" setting	Indicator in centre position	Indicator on or near "Cardboard" setting
Paper Separation	Place red side for thin paper on suckers 90° separator springs as far out as possible	45° separator springs as far out as possible	Place rubber discs on suckers. Retract front separator springs, instead place side separator springs extending slightly over edge of pile
Feed Air Blast	Reduce air blast. Blower in top position	Medium to full air blast till sheet flutters. Blower in middle position	Full air blast. Blower in lowest position
Delivery Air Blast (Air blast motor, the air flow of which is controlling the sheet when transported to delivery pile)	Reduce air blast more or less all the way, depending upon paper size and printing speed	Medium to full air blast	Little air blast necessary.
Delivery Air Blast directly above the delivery pile	Reduce air blast depending upon paper size and printing speed	Medium to full air blast so that the sheet falls quickly down on the pile	Full air blast
Cylinder Brush	Engage lightly in 1st position	Brush engaged in centre position during the first run. During the following runs engage brush as required	Brush fully engaged

Specifications for the Original Heidelberg Cylinder

		22 ¹ / ₂ x 30 ¹ / ₄ "	22 ¹ / ₂ x 32 ¹ / ₄ "
Maximum sheet size		22 ¹ / ₂ x 30 ¹ / ₄ "	22 ¹ / ₂ x 32 ¹ / ₄ "
Minimum sheet size		11 ⁷ / ₁₆ x 15 ³ / ₄ "	11 ⁷ / ₁₆ x 15 ³ / ₄ "
Largest half-sheet two up		14 ³ / ₈ x 22 ¹ / ₂ "	15 ⁹ / ₁₆ x 22 ¹ / ₂ "
Smallest half-sheet two up		8 ¹ / ₄ x 11 ¹ / ₁₆ "	8 ¹ / ₄ x 11 ¹ / ₁₆ "
Inside measurement			
Standard chase		22 ¹ / ₁₆ x 28 ³ / ₈ "	22 ¹ / ₁₆ x 30 ³ / ₈ "
Skeleton chase		22 ¹ / ₁₆ x 29 ¹ / ₈ "	22 ¹ / ₁₆ x 31 ³ / ₁₆ "
Maximum forme			
standard chase		21 ¹ / ₄ x 28 ³ / ₈ "	21 ¹ / ₄ x 30 ³ / ₈ "
skeleton chase		21 ¹ / ₄ x 29 ¹ / ₈ "	21 ¹ / ₄ x 31 ³ / ₁₆ "
between bearers		21 ¹ / ₄ x 30"	21 ¹ / ₄ x 32 ¹ / ₄ "
Gripper margin adjustable between		5 ⁵ / ₁₆ and 3 ³ / ₈ "	5 ⁵ / ₁₆ and 3 ³ / ₈ "
Length of forme from pitch line to leave with 3 ³ / ₈ " (10 mm) gripper margin		21 ⁵ / ₈ "	21 ⁵ / ₈ "
Maximum speed		4600 i.p.h.	4600 i.p.h.
Power requirements		HP 8,3	HP 8,3
Net weight	approx.	11.700 lbs	12.125 lbs
Gross weight packed	approx.	14.600 lbs	15.000 lbs
Overall length		11'6"	11'6"
Overall width including motor		6'7"	6'7"
Height to top of feeder		5'1"	5'1"
Bowl rails		4	4
Number of forme rollers		4	4
Packing thickness	approx.	.047"	.047"

Floor plan
for the Original Heidelberg Cylinder $22\frac{1}{2} \times 30\frac{1}{4}$ " / $22\frac{1}{2} \times 32\frac{1}{4}$ "

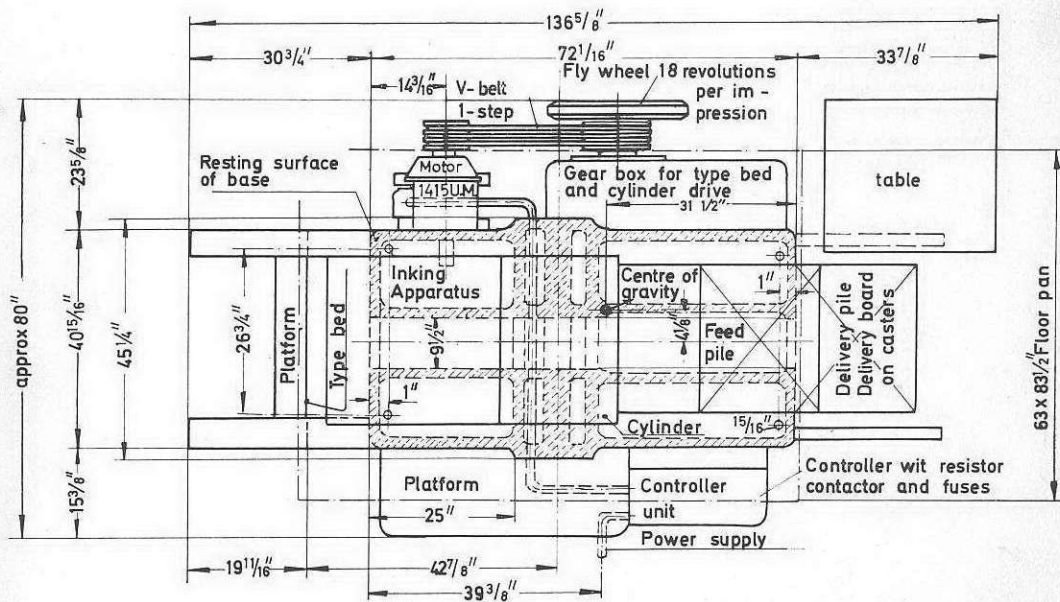
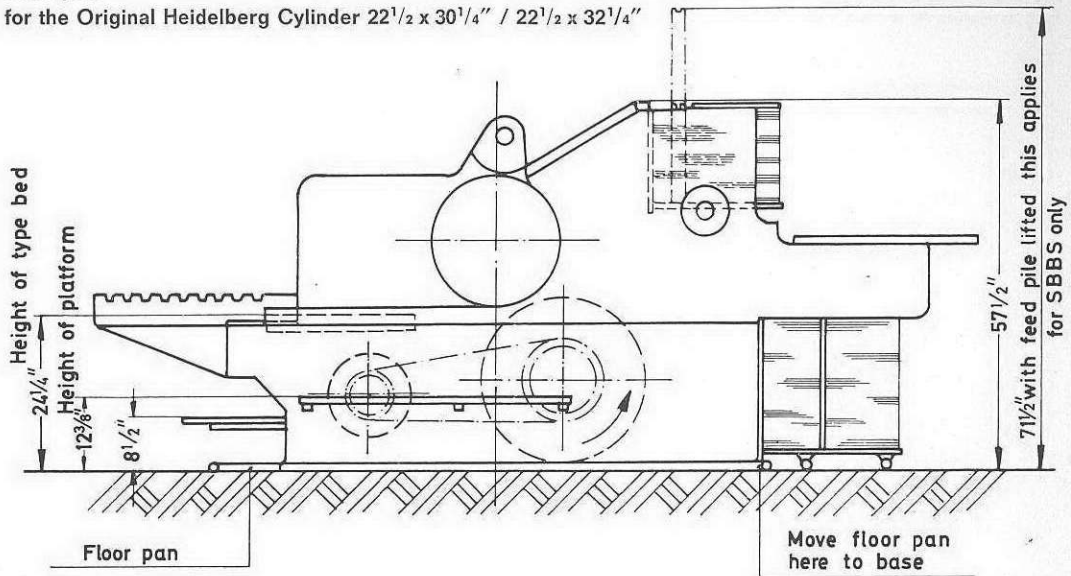

Minimum distance on all 4 sides = $25\frac{5}{8}$ " (650 mm)
Floor contact surface = 22 sqft. (2,1 m²)

Oil Drip Pan

We urgently recommend placing the machine on an oil drip pan in order to prevent soiling of the floor. This is especially important on concrete which is subject to decomposition when saturated with oil or grease.

Each stroke of the central lubrication handle forces approximately 2.4 (40 ccm) cubic inches of oil under high pressure into the bearings. The used oil which is forced out drains on the drip pan which should be cleaned weekly.

The drip pan generally comes with a rolled $\frac{1}{4}$ " or $\frac{3}{8}$ " bead and measures 63" by $83\frac{1}{2}$ " (160 x 212 mm). It is made of galvanized sheet iron.

THE DESIGN

Original Heidelberg Cylinder

Paper Size $22\frac{1}{2} \times 30\frac{1}{4}$ " (57 x 77 cm)

$22\frac{1}{2} \times 32\frac{1}{4}$ " (57 x 82 cm)

The **Original Heidelberg Cylinder** is unique in its design and construction and cannot be compared in any way with orthodox stop-cylinder or two-revolution presses. It is built on an entirely new principle, which results in the production at economic costs of the finest quality of print, at speeds previously unknown on letterpress flatbed machines.

The **Original Heidelberg Cylinder** has been installed by leading printers all over the world, which provides convincing evidence of the fact that its unrivalled advantages have been universally recognized.

The designers of the **Original Heidelberg Cylinder** planned to provide for the every day requirements of the printer and to ensure that he could successfully meet competition and rising production costs. It was clear from the start that an entirely new approach to the problems would have to be made. A machine of revolutionary design was essential. The designers did not even have to consider the machine from their own production angle, as new a plant was to be provided to meet their requirements. As a result, the demands of the modern printing house were given the first consideration.

Briefly, these demands were:

1. Greater output with improved quality.
2. Reduction in make-ready time.
3. Reduction to the minimum of idle time, to be achieved by simplicity and speed in changing jobs, forme adjustment, inking, washing-up, maintenance, and general operation.
4. High production speed, positive sheet-control and superb inking on all jobs with four forme rollers which clear the whole forme even when using the maximum size forme.

These are the principles on which the Original Heidelberg Cylinder was planned and built. The result is greater output and reduced costs.

We do not intend to produce a technical treatise regarding the principle of the Original Heidelberg Cylinder. Such a treatise would require too much space and overlook the purpose of an operation manual. We propose, therefore, to concentrate only on the points which are of technical interest for the machine-minder operating our machine and of economic importance to its owner.

The **Original Heidelberg Cylinder** is a single revolution machine of special design. Whilst with the two-revolution machine, the first revolution of the cylinder is used for the printing stroke and the second revolution for the return stroke of the type-bed, the Original Heidelberg Cylinder printing stroke and return stroke of the type-bed take place within one revolution of its large cylinder.

During the printing stroke the type-bed moves with reduced speed corresponding to the large cylinder diameter of 21" (540 mm) which was chosen. The speed reduction during printing, which results automatically in improved quality, is balanced by a proportionate increase of speed on the return stroke. As is well known, there is no printing function in any machine on the return stroke, which is an idle stroke.

Now please study the drawing on page 16 very carefully.

REVOLUTION-, IMPRESSION- AND DISTANCE-DIAGRAM

A Two-Revolution Press of same size and 4 forme rollers of same size makes 4 impressions to a distance of 8,5 mtrs

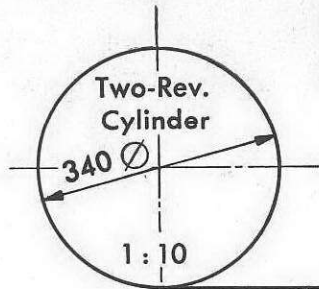

$$340 \times 3,14 \times 2 = 2,12 \text{ mtr. per impression}$$

$$\text{Scale} = 1 : 50$$

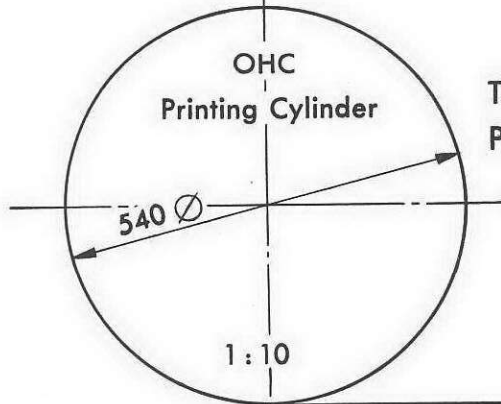
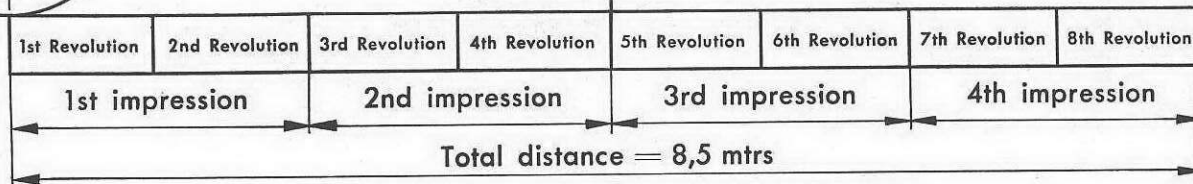

The OHC makes 5 impressions to a distance of 8,5 mtrs
 Production increase over two rev. press = 1 impression
 Increased Output = 25%

$$540 \times 3,14 \times 1 = 1,7 \text{ mtr. per impression}$$

$$\text{Scale} = 1 : 50$$

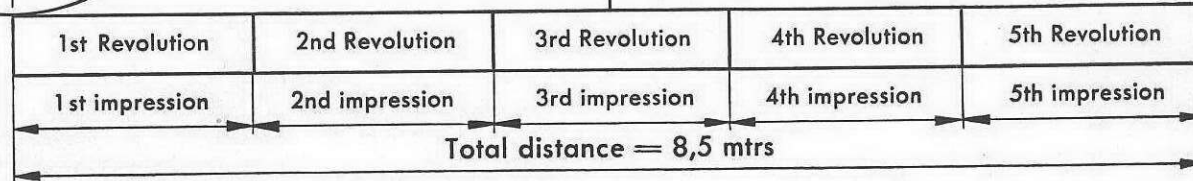

Reduction to the minimum of make-ready time achieved by rigid construction

The cylinder is ground and polished to the limits of mechanical perfection. With its bearings this cylinder weights one ton and with absolute rigidity ensured, flexure during the printing of heavy formes is impossible. The pressure of the cylinder on the bearers is greater than the counter pressure of the heaviest possible forme.

Make-ready is thus reduced to a minimum and is confined as it should be, to correcting inaccuracies in the forme alone. During make-ready, the whole of the printing area is in view and completely accessible without swinging away or removing any parts.

Illus. 1

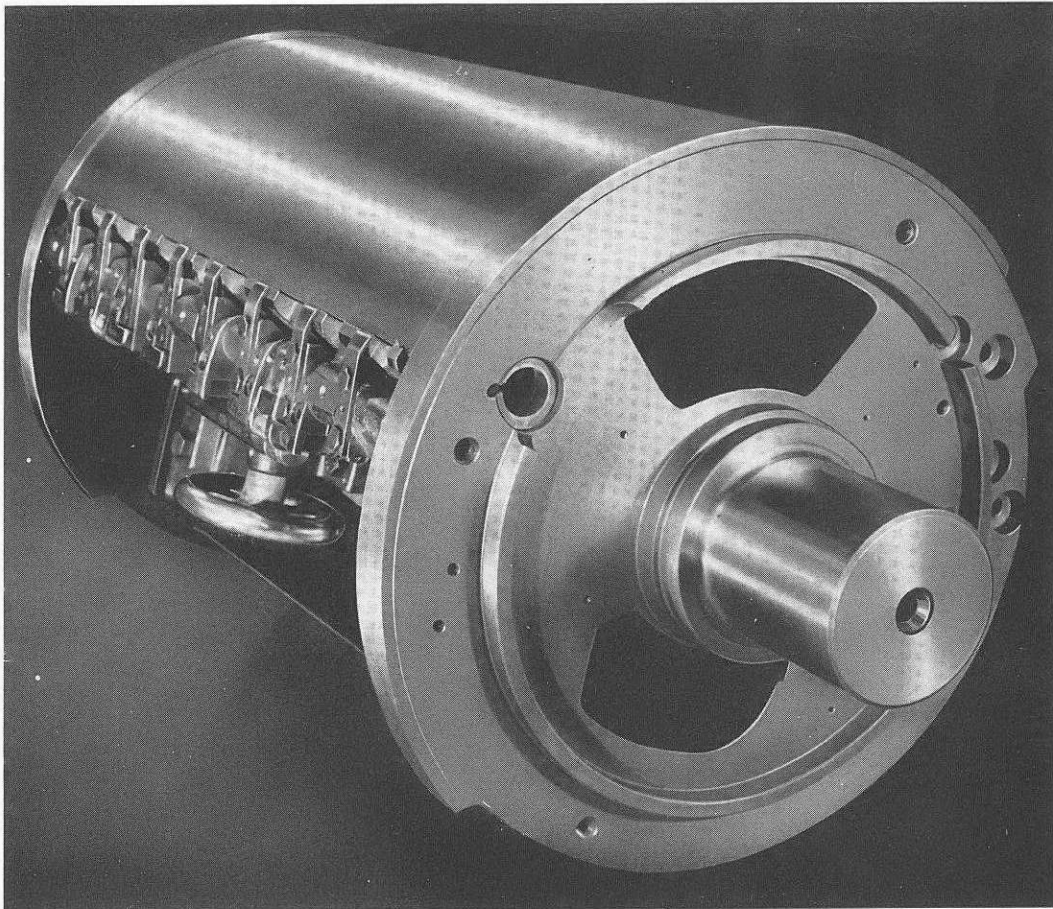

**Cutting down unproductive time for changing jobs,
and adjusting forme. Simplification of maintenance and operation**

The operation of the Original Heidelberg Cylinder is simplicity itself. A single handlever controls starting, stopping, paperfeed and impression. The complicated controls and fittings which are usually found on cylinder machines have been eliminated. There are no parts to be lifted or swung away and everything is easily accessible. The few essential controls are clearly visible and are marked with instruction plates.

All control levers connected with the starting, stopping or central lubrication of the machine are

equipped with red ball handles. The other control levers which pertain to the operation of the machine are provided with white ball handles.

Positioning the forme, adjusting feed and delivery piles, and setting the lays, are jobs which are simplified by graduated scales on the chase, feed, delivery tables and side lay.

Furthermore, a device for adjusting the formes is supplied as an extra with the Original Heidelberg Cylinder which is instrumental in further reducing

Illus. 2

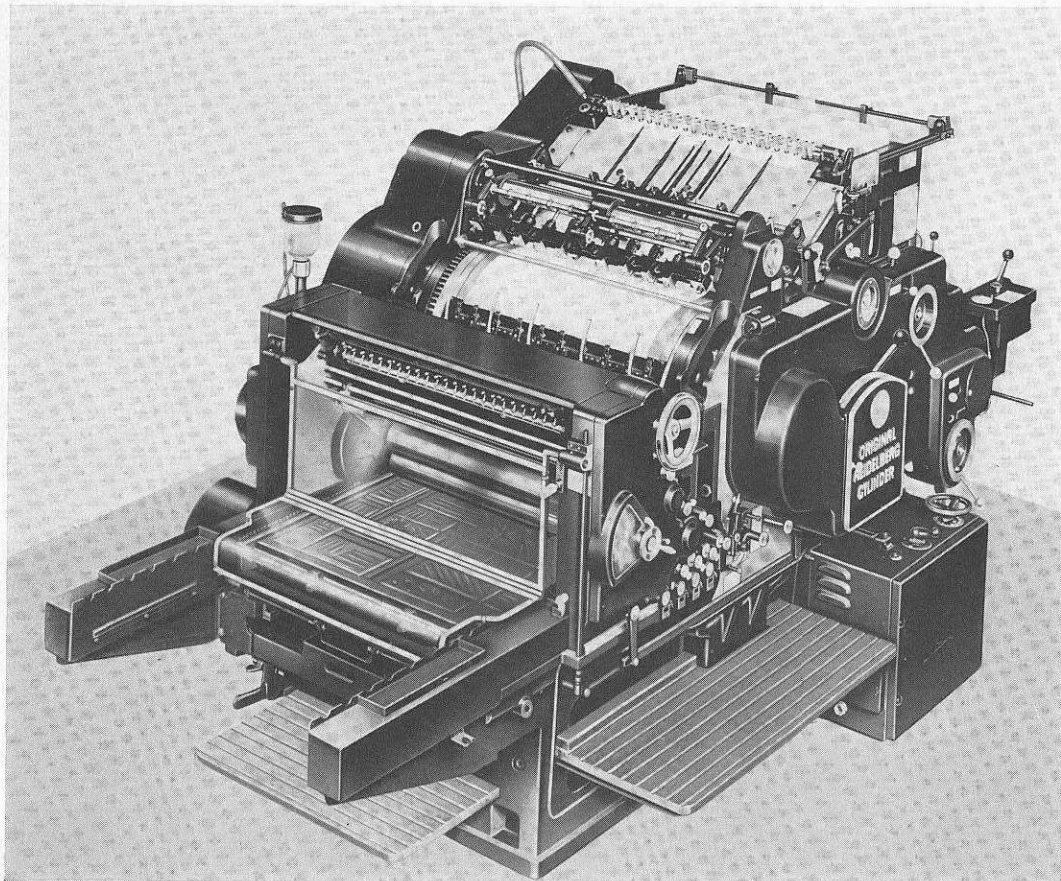

the idle time of the machine. The various blocks of multicolour work can be exactly positioned by means of this attachment — outside of the press while the previous forme is still printing. On special request we can also supply an imposing surface (composing stone) which, exactly as the type bed of the machine, is equipped with two bearers and stops as well as chase locks. This will enable the printer to completely lock, outside the press, even jobs which require perfect register.

From the feed table to the delivery pile, the sheet is controlled by mechanical grippers. These grippers need no adjustment and will deal effectively with any size or thickness of stock. The grip is variable and is $\frac{5}{16}$ " to $\frac{3}{8}$ ". The feeder itself represents a complete break from tradition, as no tapes, rollers, or similar frictional devices are employed. Four mechanical grippers carry the sheet down the feed board into the lays, and as already mentioned, they need no adjustment whatsoever. By eliminating tapes, rollers and all other encumbrances from the feed board, the danger of marking freshly printed sheets is completely eliminated. A preloading device is supplied as an extra with the Original Heidelberg Cylinder which makes it possible to reload the machine during the run. This cuts down the idle time of the machine during reloading of stock.

The feed grippers take the sheet right down to the front lays which are mounted on the swinging gripper bar. The individually sprung grippers move slowly forward and in conjunction with the side lay register the sheet. At the moment of grip, the sheet lies perfectly flat and the grippers are stationary, so that the amount of grip is not varied with the speed of the machine and perfect register is ensured. The swinging grippers then move in unison with the cylinder and transfer the sheet to the cylinder grippers. As they do not release it until the cylinder grippers have taken control of it, register cannot be lost in transfer.

A four colour process job can be put on various Original Heidelberg Cylinder machines and printed at different speeds without fear of variation in register.

By means of the device for printing two-up small sized jobs can be printed more economically. This is of importance when off-cuts are used up.

The inking system of the Original Heidelberg Cylinder has been specially designed and is driven from both sides of the machine. The thorough breaking up of the ink is carried out by four steel cylinders with different diameters, 1 vibrator and 3 rubber distributor rollers. The reciprocation can be adjusted from 0—45 mm. In order to guarantee a sufficient coverage when printing large solids the ink strip — which the vibrator takes from the duct roller — can be adjusted from 0— $3\frac{1}{2}$ " (0—90 mm) during the run so that the amount of ink can always be adjusted exactly to the printing work which has to be done.

The Original Heidelberg Cylinder is equipped with four forme rollers. **All four forme rollers clear the maximum forme.** Only machine-minders who work on the Original Heidelberg Cylinder can fully appreciate what this means in every day printing. The most delicate and difficult jobs can be produced with ease.

A further big time saver on the Original Heidelberg Cylinder is the roller washing apparatus built into the inking system. Washing up time is reduced to 5 minutes, the rollers remaining in the machine, obviating the need for readjustment after cleaning. The operator has only to sprinkle the rollers with some white spirit from the container, apply the roller washing device by releasing the lock on the handle and in a few minutes the machine is ready for re-inking.

The printed sheet is taken from the cylinder by grippers travelling at the same speed as the cylinder, placed printed side up on a sliding carriage and gently deposited on the delivery pile without any contact with the freshly printed surface. The grippers do not need any adjustment for changes in thickness or size of paper. Tapes strings or sticks are not employed as in most delivery systems, therefore, no provision has to be made for margins or gutter.

An air blower is built in the delivery and allows printing of airmail paper and all thinner stock at

a considerably high speed and with great certainty. This device naturally improves the delivery of all other kinds of stock as well. When printing thin paper the air blast can be reduced by adjusting a screw.

As a special accessory for the delivery of very light stock, an effective blower device consisting of an adjustable tube is fitted to the machine. This tube is provided with blower nozzles and can be swung over the delivery pile in any desired position. Light weight stocks can thus be run at higher speeds.

By means of the device for continuous delivery the full delivery pile can be taken away and a new

board can be inserted without the necessity of stopping the machine.

A built-in anti set-off spray eliminates any need for interleaving.

Apart from the powder spray apparatus a liquid spray apparatus of our own design can be attached. Both spray attachments can be used alternately by a simple turn of a lever.

All the main bearings and important oiling points are supplied with the correct amount of oil by two strokes of the central lubrication pump. All the electrical equipment and built-in lighting units are of the latest design.

PRINTING IN GENERAL

Correct forme alignment

The Original Heidelberg Cylinder is a craftsman's machine, precision built and absolutely rigid in all its parts. The cylinder of the Original Heidelberg Cylinder is free from deflection and remains firmly on its bearers under all conditions. Lack of such rigidity, so often found in less solidly constructed machines, greatly adds to the machine minder's task. These facts play an all important part in reducing make-ready time as the operator is not concerned with variations in the machine, but only in the inaccuracies of the forme.

It is, therefore, worth-while spending a little time bringing the forme up to a similar state of accuracy. The solid area of a block requires more impression

than the rest of the forme. It is incorrect to start with the cylinder packing at exactly the prescribed thickness. Start with a properly adjusted forme then add or take away sheets from the cylinder packing according to the impression required. The specified cylinder packing is approx. .047" (1,2 mm), including the sheet to be printed.

Block justification

The height of a block can only be accurately gauged by means of a micrometer similar to the one shown in Illustration 3. Type high rules and hand gauges are not accurate enough for modern standards.

Illus. 3

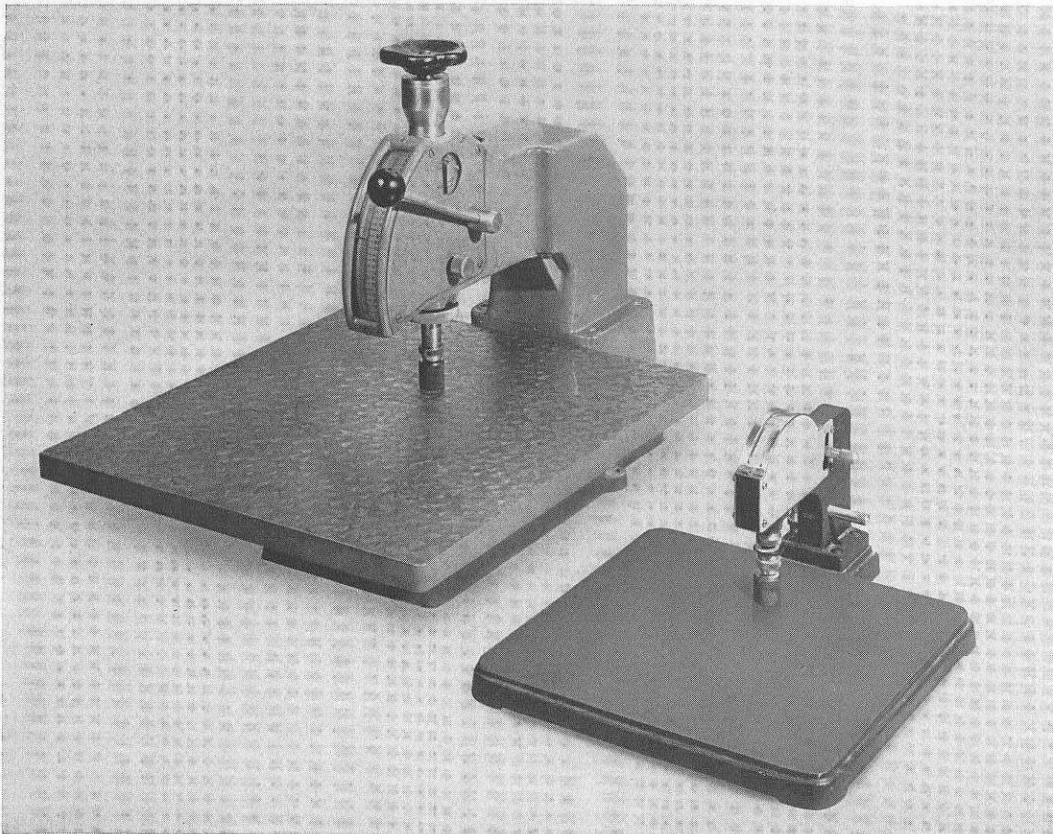

Mounting of blocks

This is a matter of great importance because many printers still fail to recognize that much of today's unsatisfactory printing results are caused primarily by poor mounting of blocks or plates. With a modern precision press such as the Original Heidelberg Cylinder at your disposal, the forme must come up to the same standard in order to take full advantage of this machine. Furthermore, a printer must remember that all makeready which has to be done on the machine is idle time. Such loss of production is needless now that a machine is available on which 100% pre-press makeready is possible.

Wood mounts

Plates that are nailed or glued to wood mounts do not come up to present day precision requirements, especially if the plate is a large one. It is possible to do a creditable job with a new accurate wood-mounted plate in a small size, but generally the results are inconsistent because of the changing nature of the wood.

Lead or iron mounts

Lead and iron mounts are satisfactory insofar as precision is concerned. However, many progressive printers will not use such mounts to any great degree because they make the forme unnecessarily heavy.

Light metal mounts

Great progress has been made in the use of light metal mounts. When put together properly, such a base can give outstanding printing results. However, the following points must be considered:

1. The assembly of light metal mounts should consist of as many large pieces of base as possible.
2. The base should not have ribbed sides, since this may cause the mounts to rise and cause slur.
3. The sides of the mounts must be absolutely square.
4. Similarly, the upper and lower surfaces of the mounts must be absolutely flat. If they are not flat, hollowness between either the block and the mount or the mount and the bed will result in a springy forme and slur trouble may occur.
5. Bearing in mind the direction of the cylinder movement across the forme, it will be appreciated that it is best to assemble the mounts so that they lie in a right angle to the cylinder axis.
6. Light metal base should be purchased only from approved suppliers. The blocks are fixed to alloy mounts with two-sided adhesive. We have found that a thin adhesive material of approximately .006" in thickness is the most suitable. This material will guarantee a firm and lasting contact with the mount. Never use a thick adhesive since there may be a tendency for the plate to slide and result in slur, excessive wear, bad register etc.

Honeycomb Base

In the past years, lightweight honeycomb base has been adopted by more printers than any other system. We will comment briefly on one type, Honeycomb Base which is made of magnesium. It is precision ground to tolerances of plus or minus one half of one thousandth of an inch.

Honeycomb Base is available in standard units from which "L" sections can be assembled to accommodate the use of both 12-point plates with conventional type or blocks. Honeycomb base can also be ordered in a complete unit secured in a quoinless chase.

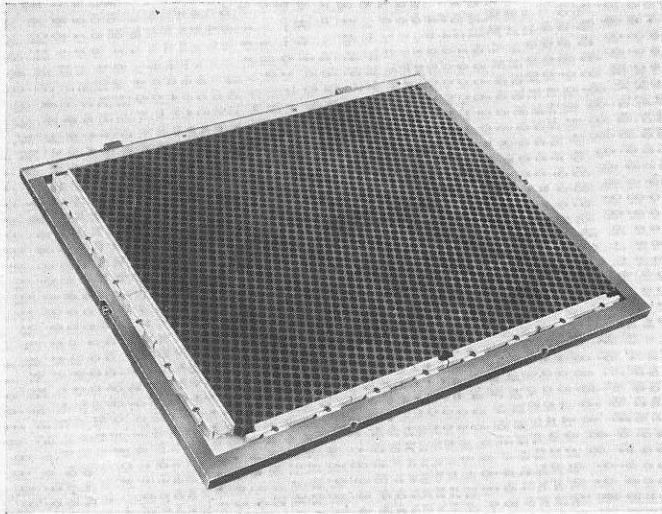

Illus. 4

Honeycomb Base gives the following advantages:

- Accurate plate positioning
- Easier, faster positioning of plates
- Better quality
- Greater forme flexibility

Honeycomb Base is made to a standard height of .744" for use with regular .166" (12-point) unmounted electros or original engravings backed up to pica thickness. Honeycomb clips are made in several different styles and sizes.

Illus. 5

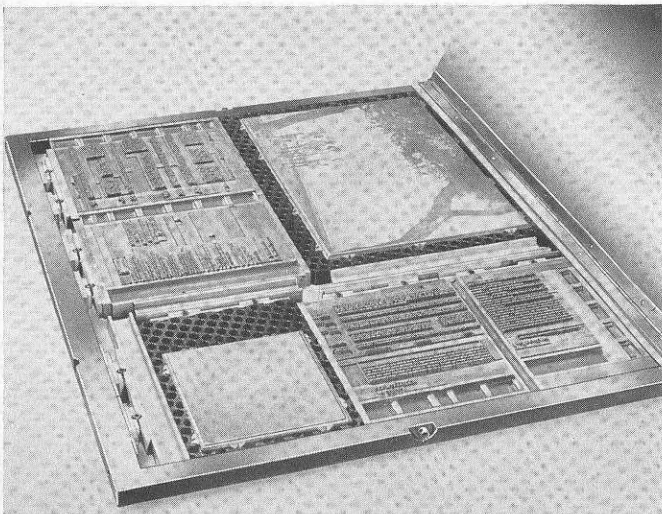

Register clips are generally used for all kinds of close register printing, and are designed to permit adjusting the position of the plates over a range of 16 points. When this limit is reached and further adjustment is necessary, the clip is taken out and put into the next hole. A wing key is employed to tighten the hooks. The drive of the Honeycomb Base register clip is calculated in relation to printer's measure. A quarter turn of the key advances the clip one point; a half turn advances it two points, and a full turn of the key advances the clip four points. The lighter weights plus accuracy mean faster change-over because of the easier, speedier handling of formes.

The basic unit of base can be used in full for a large forme of pica plates, but it can also be used in part for mixed formes. The photo on left shows a mixed forme of type matter and pica plates.

Slur

Slur is one of the most annoying difficulties the printer has to face. It is a defect that can occur on a whole sheet or merely mar the appearance of one halftone. Slur distorts dot or type face and if not remedied at an early stage, can cause considerable damage to a halftone. The causes of slur are numerous, but it only develops into a major problem when the printer is unable to detect the cause and effect a remedy. We do not propose in this book to deal with every cause of slur but to make a few helpful suggestions on diagnosis and cure of the most common varieties.

However, before we deal with this subject we would like to emphasize that oil on the bearers may contribute to slur and particular care should be taken to see that they are clean.

Slur — Ink too thin

A thin bodied ink can cause a slur on type matter, halftones and rule work. It can be detected by the filling up of the spaces between the screen dots in a halftone (Illustration 6).

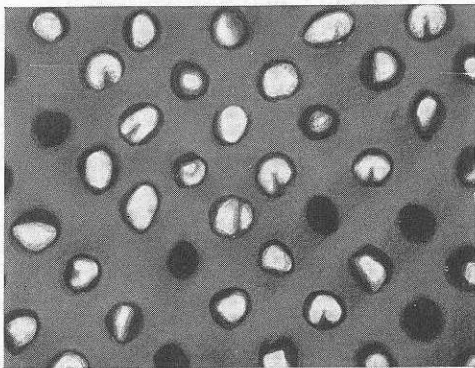

Illus. 6

This slur is usually caused by a thin bodied ink, by using too much ink with insufficient impression, or by forme rollers which are adjusted too low. Such slur is more readily detected in a halftone where the spaces between the dots are compara-

tively small and fill up more easily. The slur is not so prominent on a deeply etched halftone as the dots are more pointed compared to those of a halftone not as deeply etched. On stock with a smooth surface, this type of slur will appear more often than it will on rough stock. In colour work, a slur caused by thin-bodied ink can even make the spaces between the dots darker in tone than the dots themselves. When this slur first appears, it can be detected by small tails in the spaces of the screen (Illustration 7).

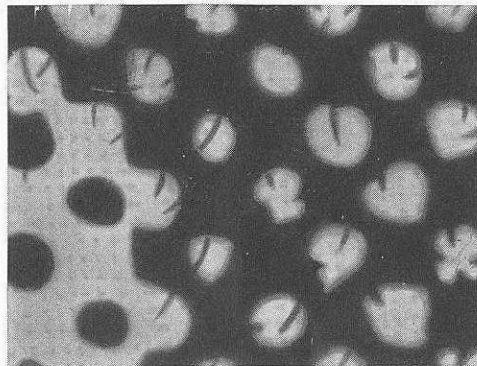

Illus. 7

Slur — Ink too tacky

The use of correct ink has bearing on the successful printing of solids and halftones with a fine screen. A slur in the printing of a solid can often be traced to the ink being too tacky. It usually produces an uneven strip of colour which runs in a curve from the leaving edge, and may be up to 1 1/2" wide. The edges of the slur are blurred. It follows that the tack must be reduced and the addition of a reducing paste will generally produce a better result. A transparent white should never be used.

Slur — Caused by forme rollers

While a slur caused by tacky ink appears on the leaving edge of the sheet, as discussed above, a slur caused by either incorrectly set or inferior

forme rollers can appear anywhere on the printed sheet. When the forme rollers are set too low a dark smudge appears on each side of a halftone. The edges of the page of type matter are blurred. The first and last lines of the page appear in a washed-out grey. A similar slur can also be caused by the rollers being uneven and not perfectly round. In this case, the slur will appear wherever the uneven part of the roller contacts the forme. This trouble may also be caused by rollers slipping over the forme, as they do when they are too hard, too soft or lifeless. In such cases, the whole area of the block will have a streaky appearance.

Slur — Caused by badly mounted blocks

If blocks are not mounted on a perfectly accurate base, it is not possible to lock up a forme precisely enough to get the best results. The material in the forme will spring towards the center, causing a slur to appear on the printed sheet. In halftones, this slur is easily recognized by an elongated dot, which points in the direction opposite to the movement of the type bed, or it can be recognized by general distortion of the dot.

If the plate is not mounted correctly, it will slip and again cause slur.

Therefore, we recommend that the plates be fastened over their entire area with two-sided adhesive on light metal mounts.

Blocks too low — cylinder overpacked

If the blocks are below type height, then the cylinder packing has to be increased to more than its prescribed thickness to get the necessary impression. The surface of the sheet then moves faster than the forme, as it is now further away from the center of the cylinder than with the normal packing. This

Slur — Caused by high or low blocks

This is a common type of slur and is usually the result of the forme not being checked for height before being put on the machine. If the blocks are not of the proper height, they are not in correct level with the cylinder radius. The machine-minder compensates for this difference by under- or overpacking the cylinder. This affects the speed ratio of the cylinder to the type bed and the halftone dots are elongated or pearshaped, pointing either to the gripper or tail edge of the sheet, depending on whether the block is too high or too low. Frequently, the printer is unable to tell if the forme is type high as he seldom has a micrometer available. As a result, the inaccuracies which are actually present in the **forme** are often blamed on the press.

An engineer uses a micrometer to determine inaccuracies in a machine or an engine. It is just as necessary for the machine-minder to use a micrometric gauge in selecting the proper amount of packing, and determining the heights of his blocks.

We should also like to recommend the use of pocket microscopes which are on the market in magnifying powers of 50 or 60 times. With these, a slur can be detected in its initial stage; that is, on the first proof. At this stage, it cannot be detected with the naked eye or with a common magnifying glass, unless it is quite a heavy slur.

causes the sheet on the cylinder to move fractionally faster than the forme on the bed and distortion or slur occurs. **The diagnosis shows the screen dots to be elongated and pointing toward the tail edge of the sheet** (Illustration 8).

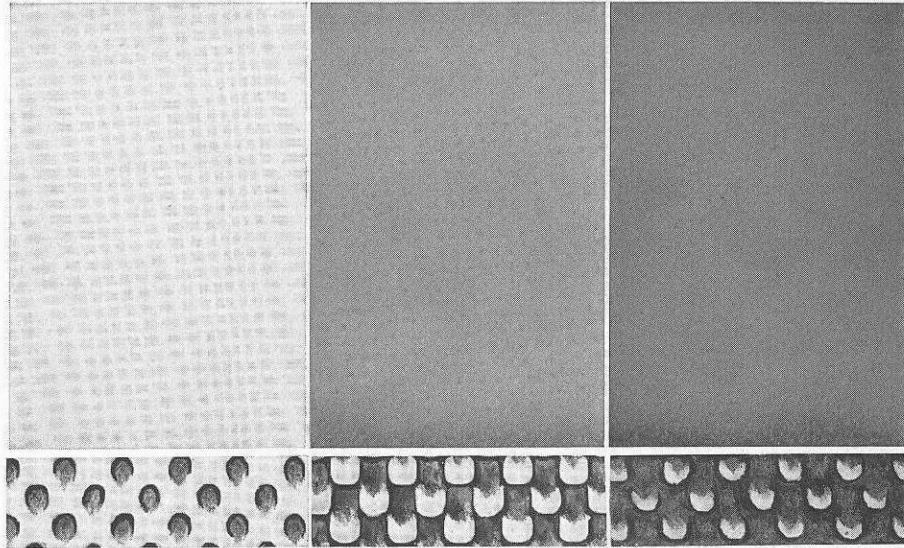

Illus. 8

Blocks too high — cylinder underpacked

Conversely, if the blocks are above type height, as a compensation the cylinder must of necessity be underpacked in order to obtain the proper impression. In this case the sheet on the cylinder moves fractionally slower than the forme. **Distortion occurs and the elongated dots point toward the gripper edge of the sheet** (Illustration 9).

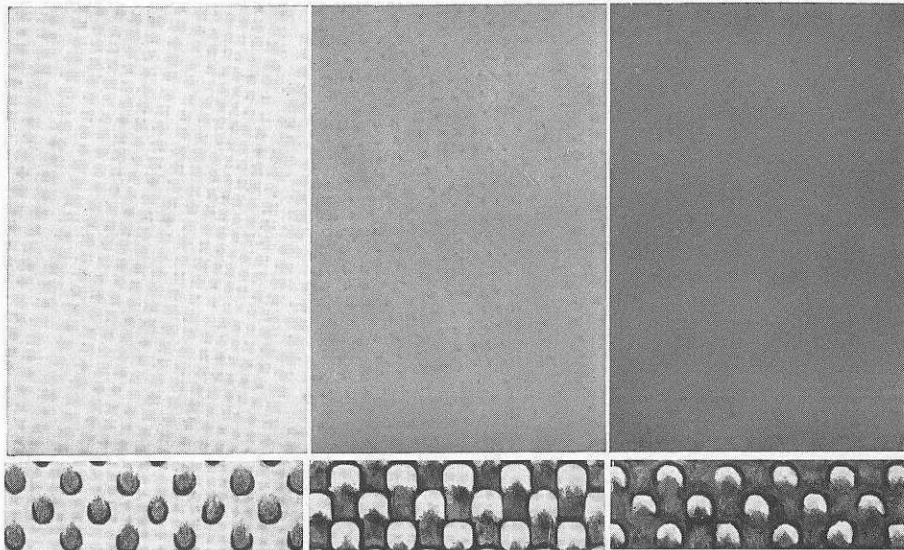

Illus. 9

Blocks at correct height

If the block is adjusted to its correct printing height the dot appears sharp and round (Illustration 10).

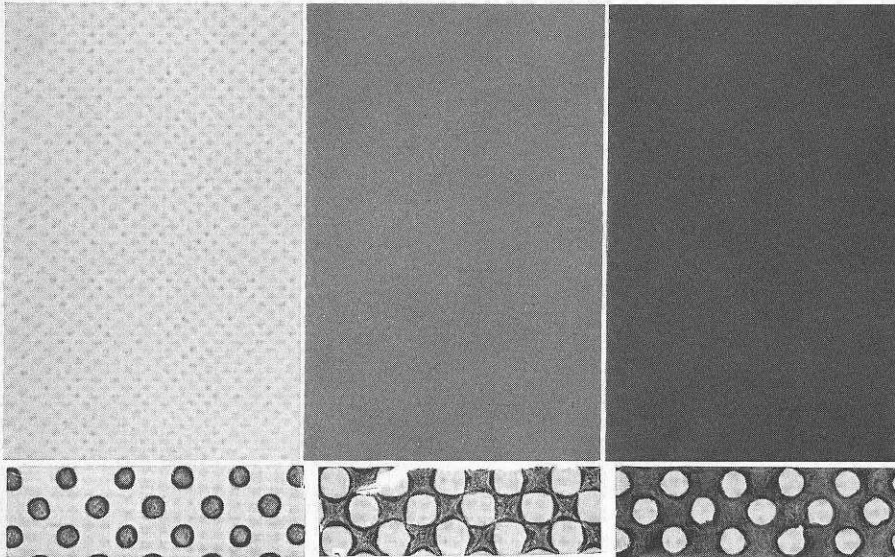

Illus. 10

Remedies

Before attempting to print, the machine-minder should examine the leaving edge of the sheet under his pocket microscope or magnifying glass. From his observations it should not be difficult to decide what he has to do if distortion of the dot occurs.

1. If he finds that the dot is slurred toward the leaving edge, the block is too low. It must be brought up to type height and the cylinder packing reduced.
2. If he finds that the dot is slurred towards the gripper edge, the block is too high. It must be lowered and the cylinder packing increased.

The illustrations show an exaggerated slur so that its direction can be more easily observed. Before running, the dot should appear round and sharp as shown in our third example. There should not be the slightest tendency to slur as this can only

mean that there is a slight discrepancy between the surface rotation speed of the printed sheet and the corresponding speed of the forme on the bed. Even the smallest discrepancy will cause damage to the forme on a long run. The point must be sharp and without a tendency to slur toward the head or the tail because only then can a large run be printed without trouble.

Tendency to slur is more easily recognized in the lighter shades of a halftone, where the dot is isolated. It is more difficult to detect in the deeper shades, where the dots cluster and the spaces between them are observed as white or negative circles. Slurring may be recognized in the deeper shades of a halftone when this "white" circle is flat on one side instead of being perfectly round. This flattening of the white circles is caused by the clustered dots slurring across them. If the circles are flattened in the direction of the gripper edge of the sheet, the slur is in the direction of the leaving edge. Conversely, if the circles are flat in the di-

rection of the leaving edge of the sheet, the slur is in the direction of the gripper edge.

The direction of the slur is always detected by the flat part of the white circle and not by a heavier deposit of ink that fails to alter the shape of the circle. This heavier deposit of ink usually occurs on the opposite side of the flattened portion of the circle. Wherever possible, check for slur on the single dot in the lighter tones, where it is more easily recognized.

Before closing this chapter on slur, we appreciate that in the past many causes of slur could rightly be attributed to faulty mechanical conditions in a machine. We are confident that the Original Heidelberg Cylinder is a machine of mechanical perfection on which, barring accidents, slurring cannot occur. **In acknowledging the printer's mechanical skill and his technical skill in the application of ink to paper, we would ask him to make certain that, when faced with a difficult case of slur, he explores every avenue before declaring the machine responsible.**

Pre-Makeready of Forme

In many printing works where four or more Original Heidelberg Cylinders have been installed, one of them has been set aside for adjusting, registering and making formes ready for printing on the other presses as soon as the formes become available. This system eliminates a tremendous amount of idle time as the locked forme and prepared make-ready can be transferred with only minor adjustments. To simplify positioning of the formes when printing multi-colour work, an extra accessory is available for the Original Heidelberg Cylinder. This permits the exact positioning of various formes outside the press. **A detailed description of this device can be seen on page 116 and the pages which follow.**

Inking

The Original Heidelberg Cylinder is equipped with rubber rollers which are supplied by a firm with whom we have been co-operating and experi-

menting for many years. It was absolutely essential to encourage long and exhaustive research because a modern cylinder press producing 4,600 prints per hour simply must have the very best in rollers.

Rubber rollers are greatly improved today. They do not show continual contraction and expansion during humidity changes. Higher speeds result in higher temperatures. Rubber, unlike other materials, will not soften and eventually pull away from the roller core. **For this reason, we recommend that rubber rollers be used on the Original Heidelberg Cylinder.** The very fine rubber rollers supplied with the Heidelberg can be used on all types of work with excellent results. The rubber roller also has a much longer life than other types.

We appreciate the fact that many machine minders are doubtful about the efficiency of rubber rollers. This undoubtedly emanates from the early days of rubber rollers when many of them were hard, had an uneven surface, lacked life and tack, and could be used only for simple jobs.

The use of rubber rollers in printing solids gives excellent results because they do not "give away" the ink after one turn as readily as other types of rollers do. Rubber has a more porous surface, which gives it an advantage in storing ink. The smooth surface of other types of rollers does not have this quality, which is particularly important when printing solids.

When printing on stocks that have an excessive amount of paper dust, many printers will make use of one plastic forme roller. This helps in picking spots off the forme. In such cases, the plastic forme roller is placed nearest to the impression cylinder since this roller is the last to leave the forme. In extreme cases, two plastic forme rollers can relieve the problem.

The Original Heidelberg Cylinder is the only machine of its size equipped with four forme rollers. All four forme rollers clear the maximum sized forme. The entire inking system gives unprecedented results.

Every machine-minder occasionally faces a job that is more difficult than the average from an

inking standpoint. It may be a solid or a particular shade of a colour or a forme that is likely to repeat. We have experimented with such problems for a long time and can prove that many inking troubles are easily overcome with four rollers of varying diameters.

On the Original Heidelberg Cylinder the forme roller nearest to the cylinder has a diameter of $2\frac{1}{2}$ " (65 mm). The next is $2\frac{1}{4}$ " (57 mm), the third has a diameter of $2\frac{3}{8}$ " (60 mm), and the fourth forme roller, which also clears the forme completely, has a diameter of $2\frac{3}{16}$ " (56 mm). Having four forme rollers, all of which clear the maximum forme, increases the ability of the machine to cope with inking problems. However, the essential need for suitable inks cannot be overemphasized. The danger of repeating exists with all colours that do not cover, and with inks having poorly ground pigment. To eliminate the resultant blemishes, such inks should not be changed in any manner which would reduce their colour strength.

A transparent white should not be used with a coloured ink whenever it can be avoided. A soft ink that is not too tacky, is preferable. Reducing oils and liquid driers should be avoided. Pastes for both purposes are recommended. In short, everything should be done to maintain the strength and covering power of the ink. When printing solids, the mixing of powdered material such as corn starch or rice flour will help the ink to lie smoothly and without mottling. It is better to start with a darker colour than is required and to lighten it with an opaque white, or with a strong lighter colour until the required shade is obtained.

The advantage of using a colour lightened with opaque white is that its covering power is not weakened.

Even with a four roller inking it may sometimes be difficult to overcome repeats or "ghosting"

when printing a certain colour tint from a large solid that is provided with a cut-out. In the lengthwise direction the appearance of a "ghost" mark is as far as possible avoided by the four forme rollers of different diameters. In order to make the side edges of the "ghost" mark disappear one puts small metal plates between the side frame of the base and the bearings for the forme rollers. These plates can be supplied as an extra accessory. When inserted they will make the forme rollers oscillate a bit in a sidewise direction due to the lateral reciprocation of the distributing rollers. This will eliminate the side edges of the ghost mark so that to the naked eye they disappear. These metal plates need only be inserted between the roller bearings on the operating side of the press.

There are also inks especially manufactured for the printing of solids. These have been introduced to the market in a full range of colour tones and are very good. If a machine-minder will follow our suggestions and those available from ink companies, every job that fits the size of the Original Heidelberg Cylinder can be put on the machine without hesitation and without experimenting and can be printed at speeds heretofore unattainable on any cylinder printing press.

Offset inks are also good for printing solids, as they have a more concentrated colour than letterpress inks. They are more expensive but recommended when printing large solids.

Ink makers also deliver inks in all colour tints which have been specially mixed for the printing of solids.

If the printer considers these indications concerning the use of the right ink he can put any job that fits into a chase of the Original Heidelberg Cylinder on the press and print it with an unsurpassed inking quality.

MAINTENANCE

Running-in the machine

Any new piece of machinery needs to be carefully run-in. The precision built Original Heidelberg Cylinder is no exception to this rule.

During the first week of operation we recommend that the speed does not exceed 3,000 i.p.h.

With each of our machines we supply an oil chart developed in co-operation with several well-known mineral oil firms. We would particularly refer you to the running-in oils for the gear box listed under (b) in the oil chart. These running-in oils are enriched with additives against wear and seizing: Do not also use Molykote additives (we are not necessarily opposed to the use of Molykote provided the specified quantities as strictly adhered to).

During normal operation, the pump handle of the one-shot central lubrication is pulled to the left twice every four operating hours. During the run-in period, we recommend two strokes of the central lubrication lever every two hours.

A careful run-in period will assure many years of trouble-free service and a minimum of wear.

Lubrication of the machine

To aid you in overall maintenance of the press, the lubrication points are divided into three groups:

1. **Daily** — all oiling points and nipples in **red** must be lubricated daily,
2. **Weekly** — all **yellow** points and nipples should be lubricated weekly,
3. **Semi-annual** — all points marked **green** require lubrication every six months.

The bearings of all inking rollers must only be lubricated with grease.

To prevent any mixup in lubrication, the oiling points have been given a different shaped nipple from those which require grease. Two different types of lubrication guns are supplied with all machines. The mouthpieces on these are different. The short lubrication gun is for oiling, while the longer one is to be used for grease points.

Oil lubrication

All bearings which must be lubricated with oil are fitted with round protruding nipples. Illustration 11, 1 shows the shorter gun.

Lubrication must be made in accordance with the oiling specifications given on the instruction plates of the machine.

Illus. 11

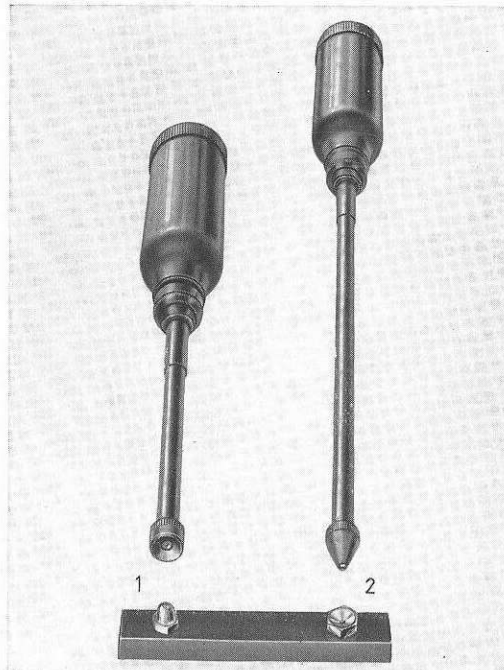

Grease lubrication

The following parts should be lubricated only with grease:

- 16 bearings for the forme rollers, ductor roller and distributor rollers. Lubricate these regularly once a week (8 bearings on each side)
- 1 lubricating nipple (yellow) at the outside of the inker side frame (operating side)
- 1 lubricating nipple (yellow) at the inside of the inker side frame (operating side)
- 1 lubricating nipple (yellow) at the outside of the inker side frame (drive side — swing-up disc guard)
- 2 lubricating nipples (red) for the bearing of the vibrator roller underneath the duct roller.

These lubricating points have been fitted with hollow type nipples and thus can be fed only by the long shaft grease gun.

It should be especially emphasized that only high quality ball bearing grease is used for the grease gun. Do not use ordinary cup grease as it has a tendency to get hard after a certain time.

About once a month the teeth of the main pinion as well as the upper gear rack below the type bed and the lower one in the base should be greased thoroughly by hand.

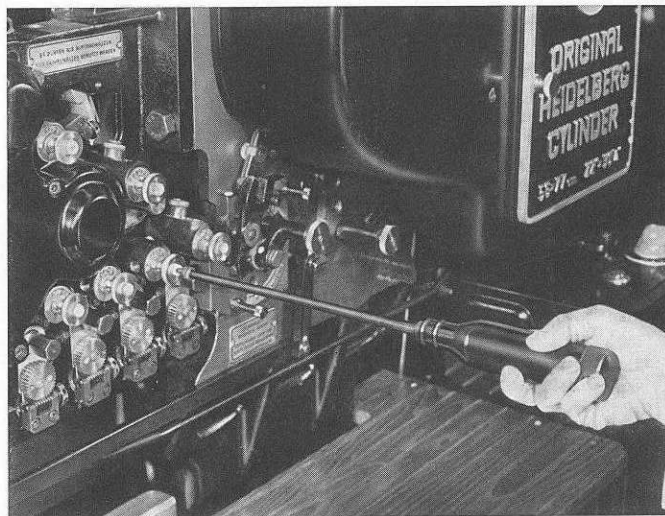

Illus. 12 shows the grease gun an the forme roller nipples.

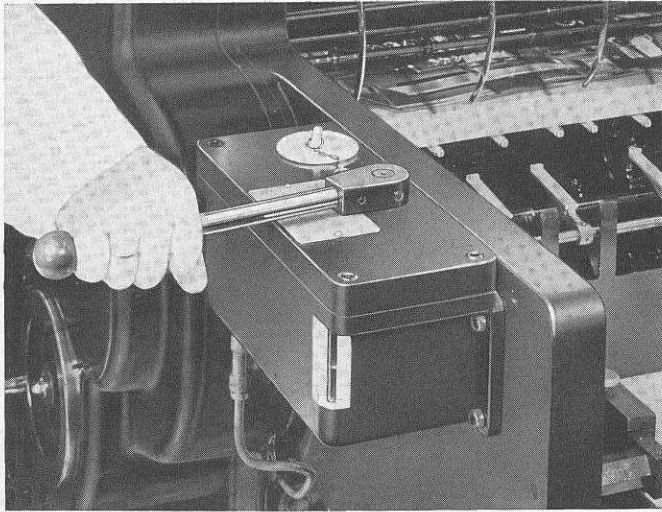

The oil reservoir for the one-shot central lubrication is fitted to the side frame of the delivery unit on the operator's side (Illustration 13).

Illus. 13

Central lubrication

The one-shot central lubrication pump supplies the exact amount of oil required to all major lubrication points.

In operating the central lubrication the following points have to be observed:

1. If the machine is idle for 2 to 3 days or longer, the red ball handle has to be pulled fully to the left least four times **before starting the machine**. About 10 minutes after starting the machine, we recommend a fifth stroke of the pump handle.

It is of particular importance to follow these instructions since the oil lines of the central lubrication system may partially drain. **When operating the lever a heavy counterpressure should build up.** The presence of this counterpressure guarantees that the oil does get to the bearing points in the desired quantity. It is therefore absolutely imperative, that the lever for the central lubrication is pulled the full distance until it reaches the red mark on the oil reservoir.

It may be necessary to operate the lever several times until the counterpressure builds up.

2. After this, the lubrication pump should be operated every four hours **while the machine is running**. We recommend lubrication when running at a low speed because this will guarantee a better oil distribution.

When the lever is operated without building up counterpressure this indicates that the oil reservoir is empty and should be refilled immediately. If the reservoir is allowed to become empty, it is possible for air bubbles to form in the oil lines. Therefore, on refitting, disconnect the oil line junction, situated alongside the bed on the operating side of the machine, and then pull the handle to its full extent several times to ensure that fresh oil penetrates to all lubrication points. Care must be taken to reconnect the oil junction as soon as it is clear that the oil flow is free of air bubbles. The oil level can be checked at the glass gauge of the pump. Should the oil level in the glass gauge get below the mark, new oil has to be added. During the weekly cleaning of the machine it is advisable to fill the oil reservoir. Please do not remove the filter. Any dirt or foreign matter getting into the system may have very serious consequences.

Gear box oil bath

A further weekly check is that of the oil level in the gear box. All gear wheels and bearings are lubricated from an oil bath that has a capacity of 14½ pints (8 l). This oil should be Energol Ref 8109 or other oils with a viscosity of 12° E/50° C.

A dip-stick is located on the flywheel side at the bottom of the gear box. The dip stick should be removed, wiped clean and re-dipped to ascertain the level of the oil while the machine is stationary. If the level does not reach the mark on the dip-stick, it should be topped up until it does, but should not be filled above the mark (Illustration 9). It may often be found that the level of oil in the gear box is above the mark on the dip-stick as oil from certain bearings which are connected to the central lubrication system drops into the gear box. **The machine should not run whilst measuring the oil level.**

A white marked hexagon screw is located at the bottom of the gear-box housing underneath the fly-wheel and should be used to drain off any surplus oil.

It is recommended to change the oil in the gear box once year.

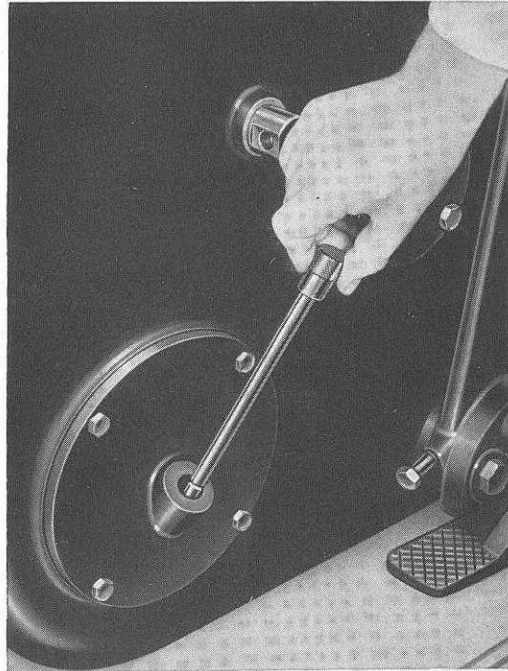

Illus. 14

Cleaning the machine

The machine must be thoroughly cleaned at least once a week. Special care must be taken to remove all spray deposit from open oil holes. All important oil holes on the Original Heidelberg Cylinder are provided with oiling nipples in order to prevent them from becoming clogged by the powder when using the powder spray apparatus. All air blast holes on the feed table and on the delivery system should be cleaned weekly with a brush.

Only use a spraying fluid that can be rubbed off with a dry rag.

When clean, all bright parts should be rubbed over with a greasy rag to prevent rust. Spraying fluids that are inclined to produce rust should not be used.

For the maintenance of the machine rust-preventive oil can also be used, e.g. "Rust-Ban 3370" manufactured by the ESSO Company.

The automatic cut-out device on the swinging gripper bar should be cleaned every three months with the cleaning fluid for the rollers. The action of the control rods should be checked to ensure they move freely.

The sludge trough and blade of the roller washing device should be cleaned daily, otherwise the ink residue will harden and the device will lose its effectiveness.

In order to avoid as far as possible paper falling into the gears as may occur when a sheet has not been fed correctly or torn sheets are contained in the feed pile; and in order to prevent accumulated spray dust from the printed sheets entering the driving system, the important parts of the machine are covered.

These cover guards are designed in such a way that they will push mis-fed sheets over the pinion shaft to the rear of the machine, where they can be removed.

Nevertheless, as the base cannot be entirely enclosed it may happen that a sheet falls into the racks. The sheet should be removed **immediately** and any small fragments of it that may still be adhering to the rack pinion recovered. The rack beneath the type bed should be checked and cleaned if necessary.

The interior of the base is accessible by removing the front guard and sliding the rear guards to the side.

If all fragments of the sheet are not taken out the prints will show slur on those parts where paper is adhering to the racks. If the run is lengthy the blocks may even become distorted.

Illus. 15

Cleaning the air filter in the suction and air pump

In illustration 15 the cover of the air pump is shown with the filter through which the sucked-in air has to pass. This filter should be screwed off every four weeks and cleaned by whirling in benzene or quick drying forme cleaning solvent into which it has been dipped. Cleaning fluid for the rollers should not be used as it contains a proportion of oil and, therefore, does not dry quickly. Finally rub the filter with a dry rag and replace it on the pump cover.

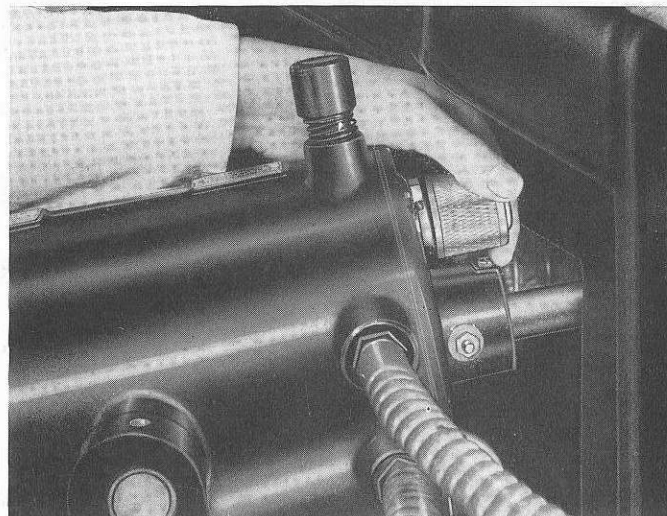

When does the printer use 2, 3 or 4 forme rollers?

The Original Heidelberg Cylinder is a general purpose machine. Its inking system has been designed for use of 2, 3 or 4 forme rollers, depending on the type of job that is to be printed. The most essential advantage is the use of 4 forme rollers on difficult halftones or solids. It is well known to printers that the ink film necessary to get good ink coverage can be reduced when more forme rollers are employed. When the ink film necessary for a given forme is assumed to be 100%, each forme roller must carry an ink film of 50% when only 2 forme rollers are used. With 3 forme rollers the figure would be 33% while the ink film for the use of 4 forme rollers would be only 25% per roller.

For machines with 2 or 3 forme rollers the ink flow from the top must be heavier in order to obtain the same coverage as when employing 4 forme rollers, where from the very beginning a smaller ink flow is possible. The distribution of the ink on the forme takes place under considerably more favourable conditions.

For this reason halftones, inked with 4 forme rollers can be run for many hours without washing the forme. The screen fills up considerably less than when the forme is inked with 2 or 3 forme rollers.

Of course, it is not always necessary to use 4 forme rollers with the Original Heidelberg Cylinder. For many jobs 2 or 3 forme rollers will give very satisfactory inking.

The following comments and drawings give more detailed information:

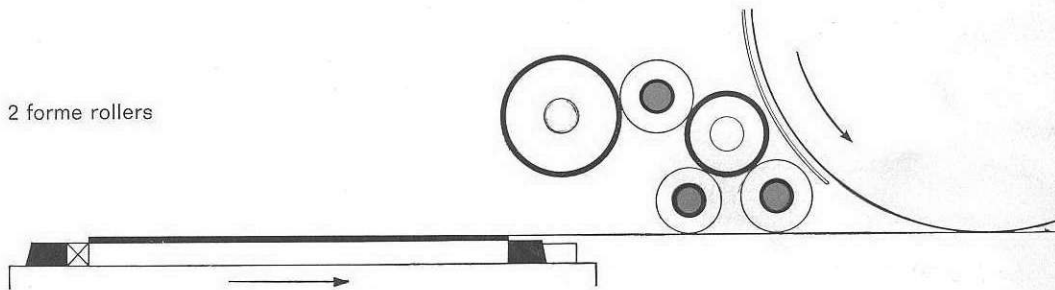

Illus. 31

Two forme rollers are generally used on simple type formes, formes with rules, or on jobs which call for plunger operated numbering machines. (On numbering work, plastic rollers are preferable since they are more resistant to cutting than rub-

ber rollers.) It is recommended that the same two forme rollers always be used on such jobs. Forme roller adjustment should be exact. If they are adjusted too low, damage will result in time from the rules and the numbering box plungers.

It is up to the machine-minder to decide whether two rollers closest to the cylinder or the second and third rollers are to be used. In the latter

combination, each roller would contact the reciprocating steel distributor roller.

3 forme rollers

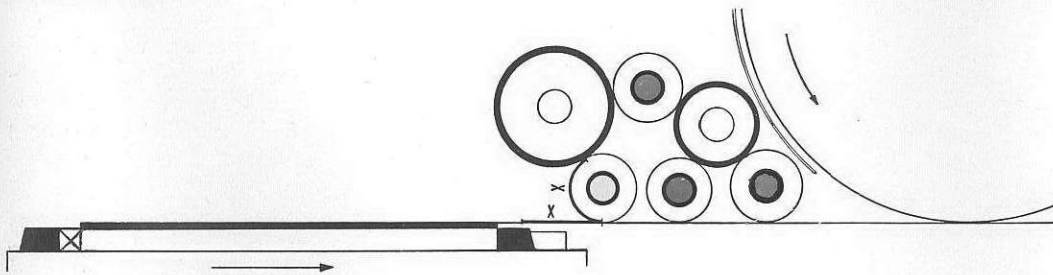

Illus. 32

General job work, especially large type formes, can be printed very nicely with three forme rollers. Adequate inking is possible since the third forme roller is inked over its entire circumference before

contacting the forme. The distance marked "X" in our diagram shows that the inking line of the third forme roller is considerably in advance of the printing line.

4 forme rollers

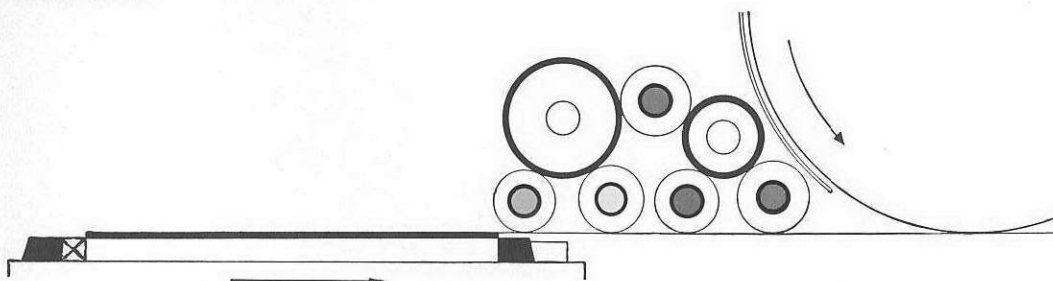

Illus. 33

Fine screen halftones, large solids or troublesome inking jobs are best handled with four forme rollers. The excellent inking system and four forme

rollers of the Heidelberg Cylinder insure coverage to meet every job requirement.

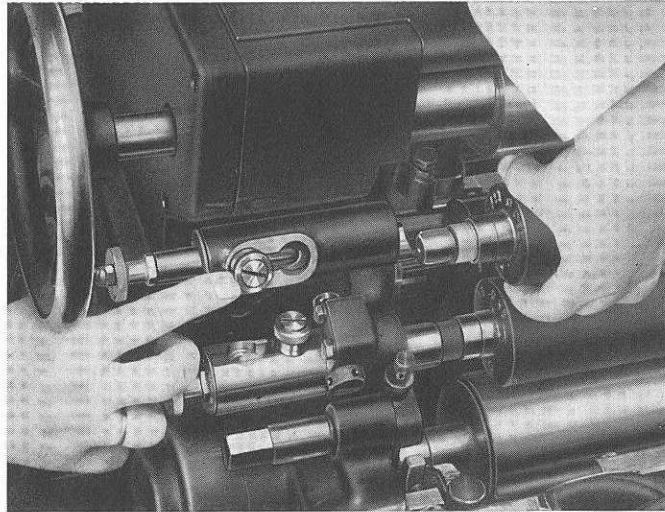

Illus. 34

Inserting rollers in the machine

The cups for the forme and distributing rollers are so designed that all rollers can be inserted or taken out without loosening or displacement of a single roller cup. All cups on the operator's side are provided with **slide-in-bushes** which can be locked in the pushed-in position as well as in drawn back position. In the working position of the rollers they have to be locked to prevent them from coming out.

When inserting the three distributor rollers and the vibrator the slide-in-bushes are first drawn back and locked. Now one roller after another is inserted, the slide-in-bushes are released and pressed to the inside. Take care that the locking bolt drops into the groove of the bearing.

Illustration 34 shows the insertion of the vibrator roller. The bearing in the drawn back position is secured by the locking bolt. After the roller end has been inserted in the bearing on the motor side the other end is put into the bearing on the operator's side. Then the locking bolt shown in Illustration 34 is raised and the bearing is pushed to the inside till the locking bolt jumps in the groove. The picture shows clearly the position of the locking bolt of the inserted distributor roller underneath the bearing of the vibrator.

Insertion of the remaining distributor and the forme rollers is carried out in the same way.

Inserting the forme rollers

1. Run type bed as far back under the cylinder as possible.
2. Pull back bearings on operator's side and engage locking bolts.
3. Start with insertion of the forme roller nearest to the impression cylinder, inserting it first into the disengaged cup on the operator's side.
4. Insert roller end in the bearing on the motor side.
5. When inserting the roller end on the motor side, the roller end on the operator's side slides out the cup as this is still pulled back. The roller end is put on the protection guard underneath the bearing.
6. Lightly lift roller end and at the same time disengage the bush of the bearing cap on the operator's side. The bearing slips automatically by spring pressure over the roller end.
7. Check whether locking bolt is fastened correctly.
8. Insert remaining rollers in the same way.

Taking out the forme rollers

1. Run type bed as far back under the cylinder as possible.
2. Pull back bearings on the operator's side and engage locking bolts.
3. The forme roller to be taken out is re-inserted with its end in the pulled back bearing on the operator's side.
4. The roller end slid out of the bearing on the motor side during this operation is swung a bit and the roller again pulled out of the bearing on the operator's side. The roller is now free on both ends and can be taken out of the machine.

Taking out the distributor rollers

When taking out the remaining rollers the various locking bolts are disengaged first, so that the bushes can be pulled back. The locking bolts then drop into the grooves provided for this position and keep the bushes back. Now the rollers can be taken out one after another.

The bearing cups which have been adjusted and screw should not be loosened to avoid a refixed in their position by means of a hexagon adjusting of the rollers after the new insertion. It goes without saying that the rollers, marked by grooves in the usual way, are always inserted in the same bearings as **minor** differences in diameter exist.

Taking out the rubber rollers, and the forme rollers in particular, is necessary only once a week in order to clean them thoroughly. This is a further advantage of the rubber rollers.

Adjustment of the vibrator

The vibrator is pressed against the duct roller on both sides by means of springs compensating automatically differences in diameter. The contact of the vibrator with the inking cylinder, however, has to be adjusted carefully as the move-

ment of the vibrator to the inking cylinder is carried out positively. The adjustment is shown in illustration 35.

Before starting the adjustment run the type bed about 8" (20 cm) ahead of the dead centre position on the inking apparatus side. In this position the vibrator should be in contact with the inking cylinder.

Underneath the end of the duct roller a hexagon screw with nut can be found on both sides. The hexagon screws are adjusted on both sides in such a way that the vibrator is in light contact with the inking cylinder then the counter nut can be tightened. The correct contact of the vibrator with the inking cylinder is checked in the usual way with two paper strips, i. e. they are put on both sides between vibrator and inking cylinder. The adjustment is correct when the paper strip can just be pulled out slowly without tearing off.

Illus. 35

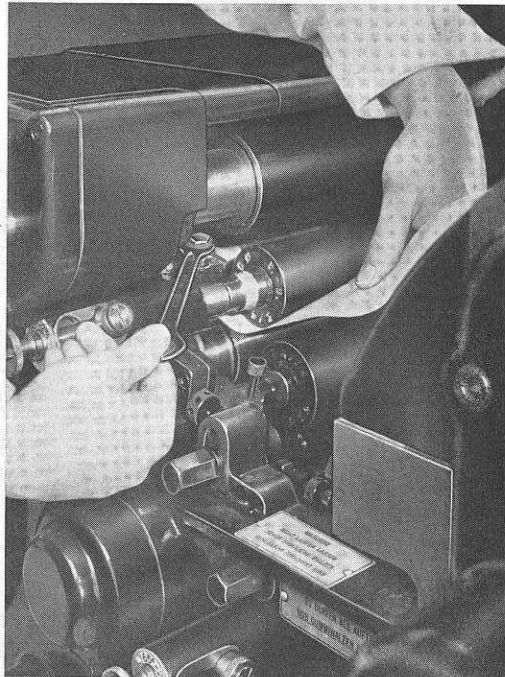

Adjusting the distributor rollers

The three distributor rollers are each located between two inking cylinders and have to be adjusted in such a way that each distributor roller equally contacts the two inking cylinders. For correct adjustment, loosen adjusting screws on both bearings. The distributor roller can now be brought in contact with one inking cylinder. The adjustment with the second inking cylinder is done by turning the eccentric bearing by means of the set screw with worm gear located at the inside of the inking apparatus. This lifts or lowers the roller.

Illustration 36 shows the set screws with the worm gear and further demonstrates that the centre of the roller is marked with a red point on the worm gear. According to the motion of the point it can be noticed in which direction the roller is adjusted. It is self-explanatory that the roller bearing should not be tightened while making this adjustment, i. e. the set screw with hexagon head remains loosened till the roller touches both inking cylinders. The correct adjustment is checked in the usual way by means of two paper strips. When the distributor roller is in correct contact with both steel cylinders the roller bearings are tightened with a box spanner. Finally the stop screws — which can also be seen on illustration 36 — are adjusted so that the correct alignment will not be lost.

Illus. 36

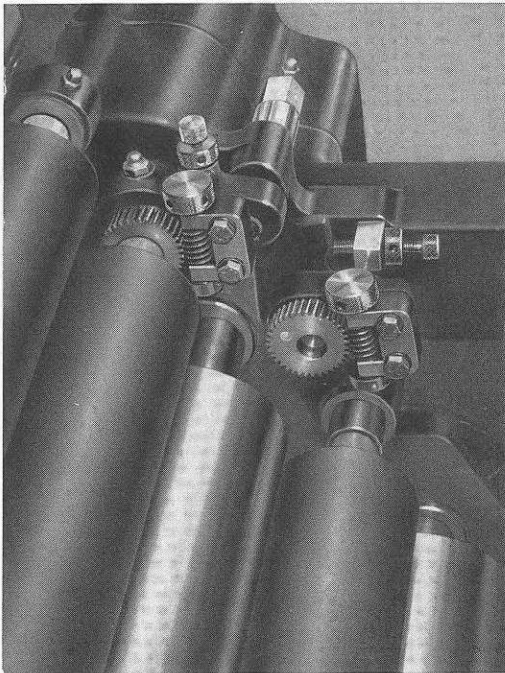

Adjusting the forme rollers

The forme rollers have to contact the inking cylinder and be adjusted to type-high. First loosen the set screws of the bearings on motor and operator's side by means of the special spanner delivered with the machine (see Illustration 37).

When the bearings are loosened, with the aid of an assistant, press the bearings with the roller equally against the inking cylinder on both the motor and the operator's side till the roller touches the inking cylinder.

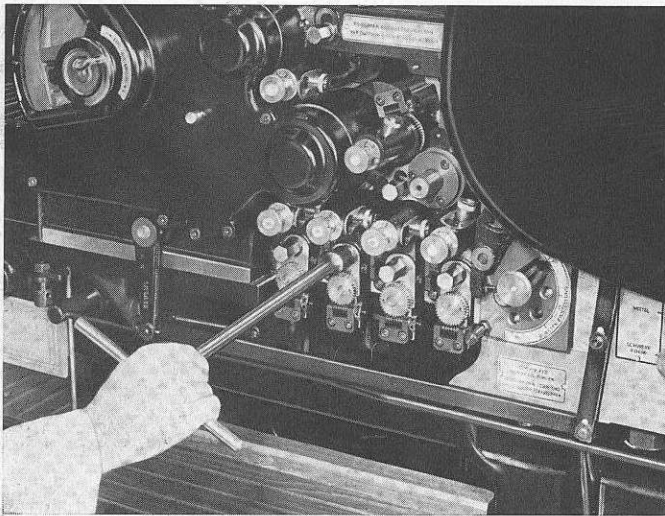

Illus. 37

With the type high gauge supplied with the machine the roller is adjusted to type high. Each roller can be tested without removing any from the machine, i. e. each one can remain in the machine during the test. This is of importance when the correct adjustment of a single forme roller is to be checked.

Insertion of the remaining distributor and the forme rollers is carried out in the same way.

To facilitate handling the gauge properly a white mark has been recessed into the handle. The gauge is in the correct position for checking the rollers when the white mark is turned up. When the gauge is inserted the mark cannot be seen from the top.

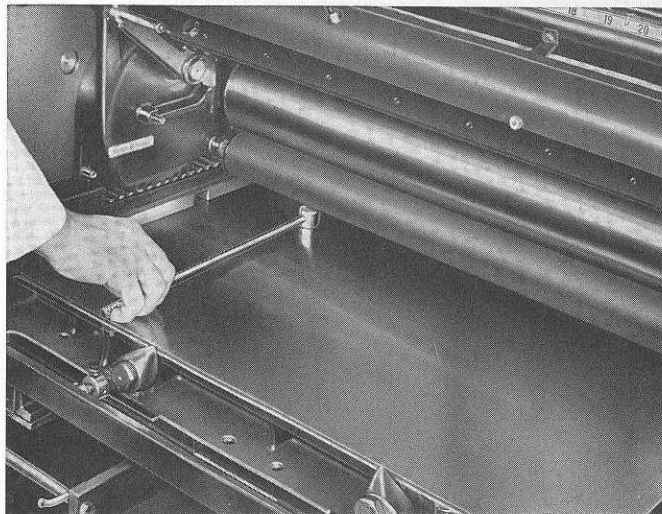

Illus. 38

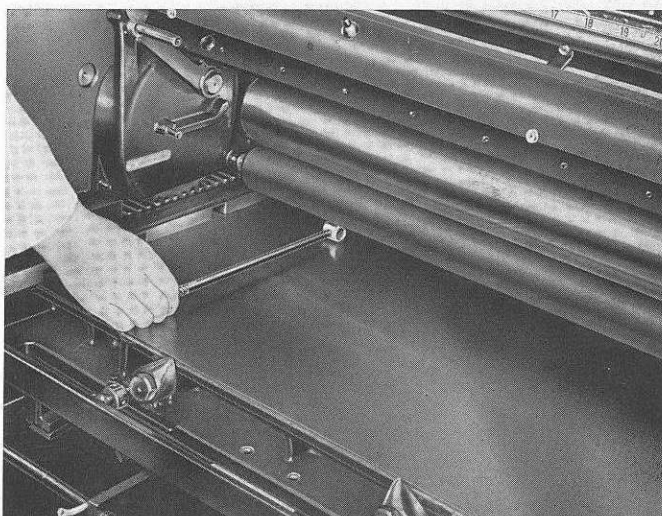

Illus. 39

Having adjusted the rollers to type-high, the contact against the inking cylinder has to be checked once more and corrected if necessary. The gauge is put on the type bed with the flat side and moved in this position behind the roller to be adjusted (Illustration 38). The height of the flat side is lower than type high so the gauge can be put in without touching the roller. The gauge then is turned to bring the round portion on the type bed (Illustration

39). In this position the gauge is exactly type high. It is now moved forward or backward beneath the roller. Before being pulled out, the gauge is turned again on its flat side so the pressman can check the ink strip on round portion from contact with the roller. The width of the ink strip should be approximately $\frac{1}{32}$ " (1 mm). Since the adjustment of the roller for height is based on the ink strip on the gauge, the roller must be inked.

The adjustment in height of the rollers themselves is effected by turning the micro-adjusters with a tommy bar as much as needed (Illustration 40).

The micro-adjuster again operates a worm drive at the eccentric roller bearing which lifts or lowers the roller. This worm gear, too, is provided with a red point showing whether the roller is

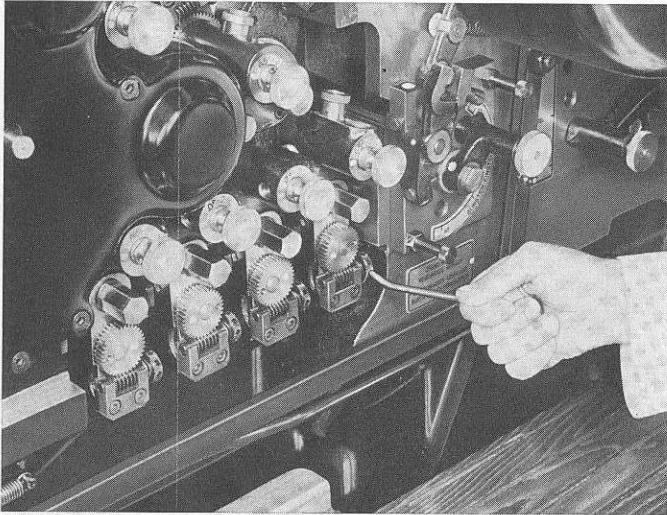

Illus. 40

lifted or lowered. After correct adjustment of the roller, the bearings are tightened with the box spanner and the stop screw at the bottom of the bearing is turned against its stop and locked.

Disengaging rollers

Disengaging the rollers is generally only necessary during a long stop or over night. For this purpose the hexagon screws of the bearings are merely loosened on the operator's side with the box spanner. The bearing with the roller has to be moved back from the cylinder and the set screw of the bearing slightly tightened. It is sufficient when the pressure of the rollers against the inking cylinder is eased. For engaging the rollers the operation is done vice versa.

The vibrator roller is disengaged when the type bed is in its dead centre position at the inking end. In this position all forme rollers clear the forme. It is recommended that the machine should be left in this position when it stands idle for any length of time.

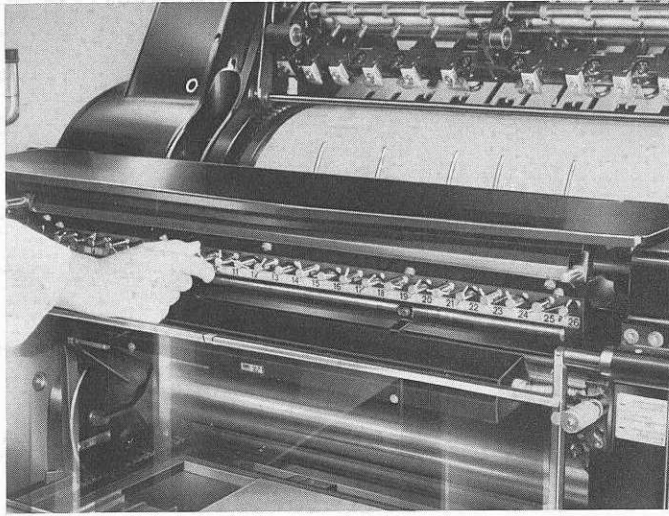

Regulating the knife and ink strip

The ink knife is regulated by 24 fine setting screws which can be adjusted to suit the requirements of any forme. The scale on the ink duct is reproduced on the delivery table. The two scales enable the operator to regulate the ink supply with accuracy.

Illus. 41

Illus. 42

The duct roller has an adjustable ink feed from 0—3½" (0 to 90 mm) which can be adjusted infinitely by turning a small handwheel on the operator's side (Illustration 42).

It is advisable when setting the ink at the beginning of a run, to work as much as possible with the regulation of the ink strip rather than with the setting screws on the duct. Better distribution is obtained as there is a thinner film of ink to break up.

The plexiglass guard can be removed for cleaning.



Engaging and disengaging ink supply

It has previously been explained that the single lever control automatically trips the ink supply when the control lever is off impression.

When, however, the ink is to be run up with the control lever off impression or it is necessary to trip the ink supply when the control lever is on impression, a lever located on the side frame of the inking apparatus has to be employed accordingly.

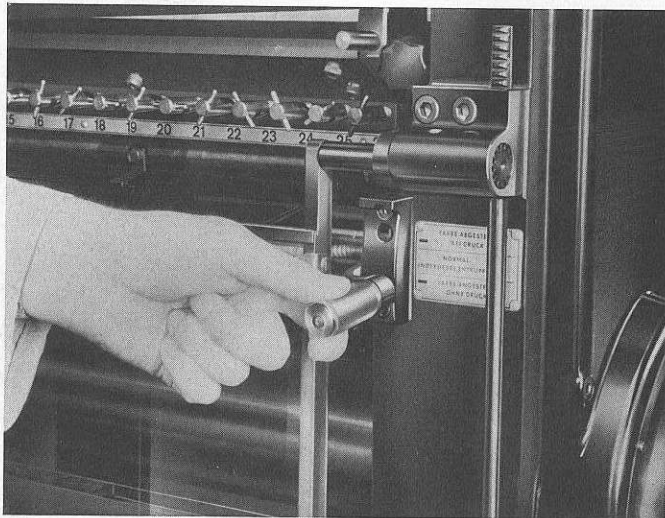

Illus. 43

If the lever is engaged in "INK OFF" position the ink supply is tripped, even when the control lever is on impression. If the lever is engaged in "INK ON" position the ink is supplied even when the machine runs off impression (Illustration 43).

Normally the lever remains in disengaged position otherwise the automatic function will not operate.

Regulating the reciprocating rollers

The four steel distributors (3, 5, 7 and 9 see illustration 31 on page 52) with different diameters reciprocate in opposite directions. Reciprocation can be adjusted from 0— $1\frac{3}{4}$ " (0—45 mm).

The regulating mechanism is located on the drive side behind a disc guard which can be swung upward (Illustration 44).

Loosen the hexagon bolt with the box spanner (which is also used for locking the forme rollers), set the indicator on the required reciprocation and retighten the hexagon bolt. The amount of reciprocation depends on the requirements of the job. Solids or reverses that tend to repeat often need all the reciprocation that can be obtained. Most jobs, however, can be inked satisfactorily with a reciprocation of $1\frac{3}{16}$ ". Reciprocation does, of course, mean added wear on the rubber rollers. So maximum reciprocation should be used only when absolutely necessary.



Illus. 44

Operating the automatic washup

The roller washing device is based on the principle of applying a blade to the second inking cylinder from above. The blade is brought into contact with the cylinder with a lever on the side frame of the inking unit on the drive side. To operate the roller washing device proceed as follows:

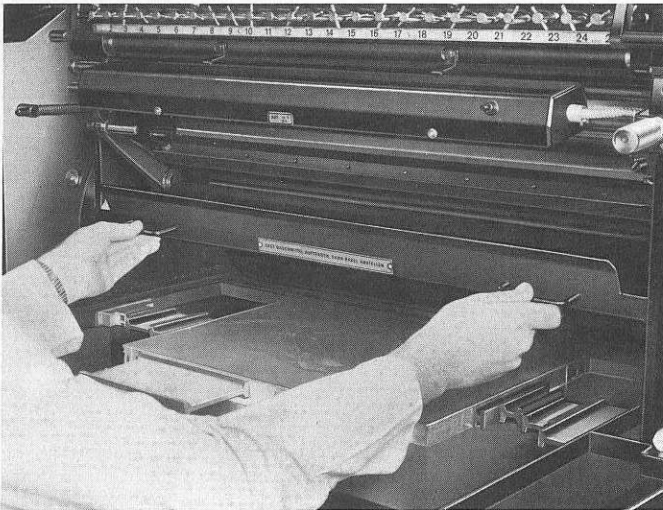

Illus. 45

1. Insert the sludge basin (Illustration 45).
2. Set the control lever in "RUN" position. The ink supply is automatically tripped provided that the lever for the ink supply is in its normal position.
3. Set the speed control at the lowest speed.

Do not engage the washup blade before you have applied washing fluid to the rollers.

4. Take the plastic tube leading from the glass container and hold the nozzle between the thumb and middle finger. Close the nozzle with the index finger so that the fluid cannot spurt out when the nozzle is below the level in the glass container.

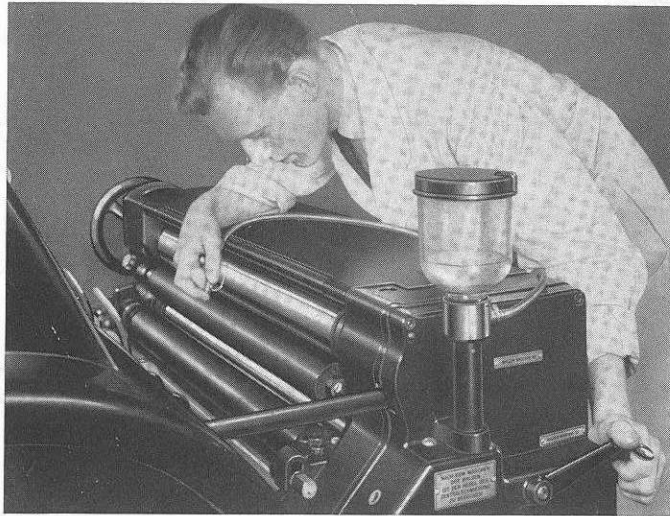

Illus. 46

5. Hold the nozzle above the rollers, remove index finger and allow the fluid to run on the rollers. It is advisable to start cleaning one half of the rollers from one side, then repeat on the other side. This insures just enough roller friction necessary for cleaning (Illustration 46).

6. The lever for applying the washup blade is positioned on the side frame of the inking unit below the cleaning fluid container. Normally this lever is on position "ROLLER WASHING OFF" (Illustration 47). When the lever is put on position "ROLLER WASHING ON" the blade is engaged (Illustration 46).

The blade removes the ink sludge from the inking cylinder in a manner similar to a wiper blade cleaning a windshield.

7. Continue applying small quantities of fluid until the rollers are clean. Do not engage the blade to the **DRY** inking cylinder.

Care should be taken that no washing fluid is spread on the roller cores, as this may result in a washing out of the oil film in the roller bearings due to the reciprocating move-

ment of the distributing rollers. After the wash-up the pump lever of the central lubrication should be operated.



Illus. 47

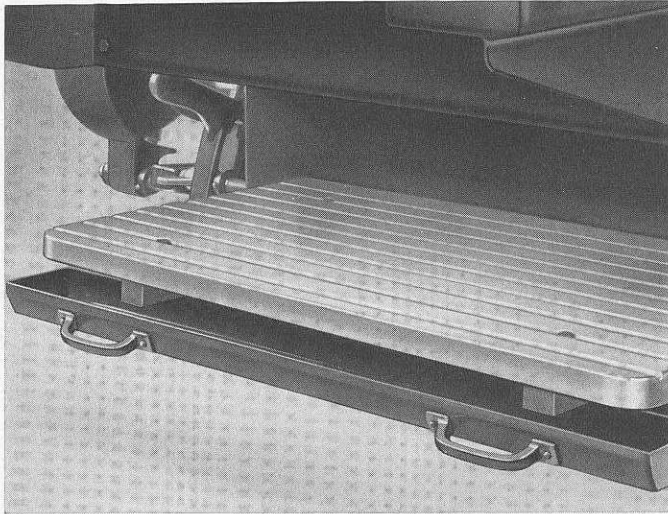

Illus. 48

9. It is not necessary to clean the sludge trough each time the rollers are washed. However, it should be taken out and put on two angles underneath the footboard at the rear of the base (Illustration 48).

It is practical to clean the blade after each washup. This will prevent sludge from drying and hardening on the blade making it rather difficult to clean.

For easy cleaning, the blade can be dropped downward by pulling down a lever inside the side frame (Illustration 49). When cleaning the blade with a rag, be sure sludge does not drop on the forme since the sludge basin is out when the blade is being cleaned.

The lever must be returned to its previous position after cleaning has been completed.

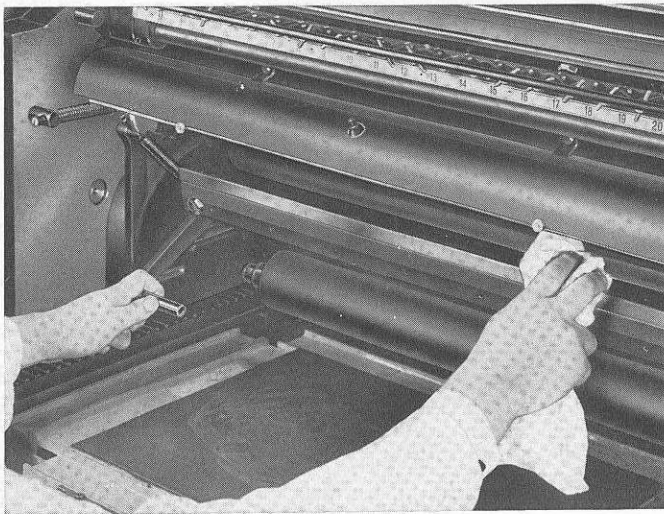

Illus. 49

After washup the machine minder merely engages the ductor roller, runs up his ink and continues the run. During a long stop, all rollers should be disengaged.

When washing up for a colour change, say from black to yellow, the operator first washes off the black ink. He then places a little yellow ink on the ductor roller and runs up the ink until it is evenly distributed. He then washes up again.

It is advisable to reserve one set of rollers for printing the dark colours, such as blue and black. The other set is used for the lighter colours, such as red and yellow. This will facilitate roller washing and reduce the time taken for washup. Ink and roller manufacturers sell proven roller washing fluids. Under no circumstances should fluids which contain aromatic hydrocarbons, such as carbontetrachloride and trichloroethylene be used. These agents attack the rollers. Be sure that containers are plainly labelled so that the forme and type cleaner is not mistaken for washup solution.

We recommend a fluid that is dyed, making mistakes impossible. White spirit is suitable for roller washing.

After washup, the forme should be cleaned with a brush and type cleaner in the usual manner. **The entire inking system should be thoroughly cleaned once each week. The rollers should be removed and washed by hand. This particularly applies to plastic rollers. The washup blade should be cleaned carefully.**

Rollers should be treated with a rubber roller conditioner or a regeneration paste (like Rollo-paste) after the weekly cleaning. The paste should be kept on the rollers at least twelve hours. It is washed off with a rag soaked in lukewarm water. The life of the rollers is considerably extended by such treatment.

Plastic rollers should not be treated with regeneration paste since the paste will attack the surface of the plastic material. However, plastic rollers should be cleaned with special care at regular intervals.

Cleaning the duct and the ductor blade

The ink duct is provided with two handles and can be dropped down after unscrewing two knobs and swinging the two latches upward. The duct roller and the ink blade are then well accessible for cleaning (Illustration 50).

Before swinging back the ductor plate apply a drop of oil to the end faces of the ductor roller to prevent seizing on the end plates of the duct.

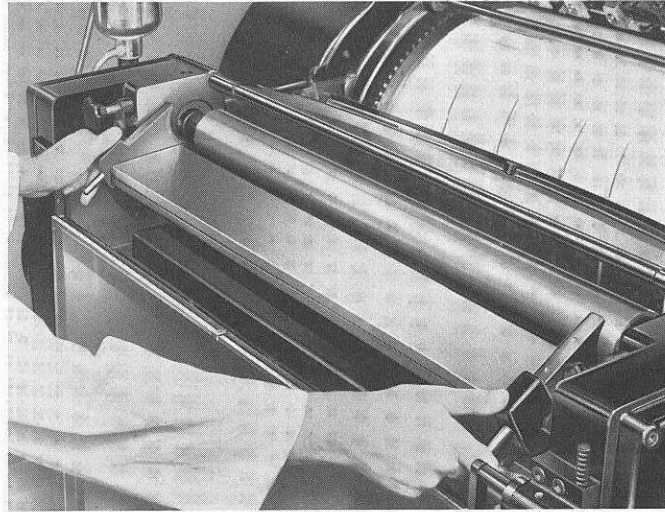

Illus. 50

Illus. 51



Cleaning the splash guard

There is a splash guard fitted between the impression cylinder and the inking system. This guard prevents ink from getting on the cylinder during the run.

The guard fits in guide rails on the drive side and operator's side. To clean, it is pulled out after raising the sheet guide bar. Removing of the splash guard is done without the use of tools (Illustration 51).

No lock or safety mechanism is necessary.

Before removing the guard, stop the machine with the tympan reels toward the ink fountain. Otherwise the cylinder segment gears could make it difficult to replace the guard.

Positioning the forme

The positioning of the forme, setting the lays, and positioning the paper on the feed table are greatly facilitated by graduated scales on the chase, side lay bar and feed table. Markings on the chase bar (Illustration 52) also indicate the position of the cylinder grippers, feed table grippers, the four front lays, and the limits of the two side lays. The scales and markings enable the forme to be locked up correctly relative to the sheet, lays and the various grippers.

When locking up the forme, care should be taken that the type matter does not exceed the maximum from inside the chase to the leaving edge. As an extra precaution a line will be found on the type bed indicating the printing limit. The following points should also be taken into consideration when positioning the forme in the chase. When a sheet has to be backed up, always use side lay on the operator's side first as it is more conveniently reached. When printing two-up, both side lays are employed.

If the sheets have to be backed up when printing two-up, an additional side lay can be inserted in the middle of the table (see page 111).

After the forme has been positioned, a sheet of the paper the job is to be printed on, is laid on in its position. From the scale on the chase, a reading (say 28) can be obtained. The feed table is adjusted to the same reading so that the sheet is fed into the lay in the correct position. The side lay is also adjusted to 28 on the graduated bar on which it is mounted. The reading for the side lay should be taken from the inside of the bracket on the graduated bar. This setting automatically allows for the lateral movement of the side lay.

Of the six front lays provided, only two are employed at a time, the remaining few should be adjusted so that they do not make contact with the sheet. The size of the sheet determines which two front lays will be employed, and the forme should not be positioned so that they come on the extreme ends of the sheet, or register will be affected.

With a full size sheet the first and sixth lay, should be used.

The gripper bite has also to be taken into account when positioning the forme, this varies from $\frac{5}{16}$ " to $\frac{25}{64}$ " (8 to 10 mm). The permanent front lays have a $\frac{3}{8}$ " (2 mm) adjustment. Position the forme so that adjustment in each direction is possible.

Good quality metal quoins and accurate furniture avoid loss of time through rising spaces and springing blocks which cause slurring.

In order to facilitate positioning and adjusting the formes when printing multi colour work, an extra accessory is supplied with the Original Heidelberg Cylinder which allows to position exactly the various formes outside the press. A detailed description of this adjusting device can be found on pages 116-121.

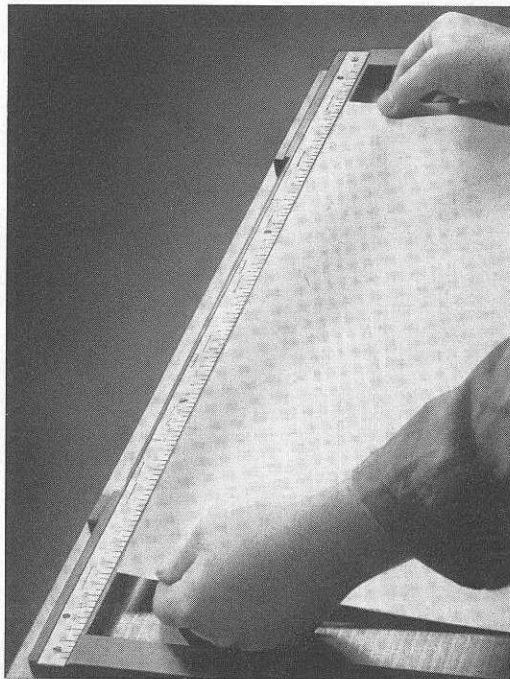

Illus. 52

Locking the forme on the bed

The rack guards on either side of the bed are provided with two ledges on which the metal imposing board can be mounted and pushed forward, so that it lines up with and contacts the bed of the machine. The bed of the machine is run out as far as it will go for this purpose. The imposing board greatly facilitates the handling of the forme as it can be slid from the imposing board to the bed of the machine with ease.

As soon as the forme is on the bed and the imposing board removed, loosen all quoins in the forme and swing the two chase locks, which secure the forme to the bed, into position. Tighten and lock with a tommy bar (Illustration 53).

Illus. 53

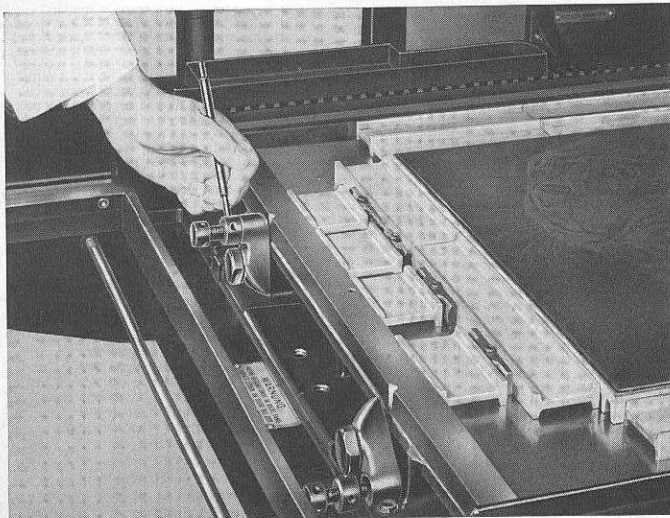

Sunk into the two side bars of the chase are two round-headed set screws which when screwed outwards, by means of a tommy bar, make contact with bearers and prevent the chase from springing when it is relocked.

They furthermore ensure that the chase can be replaced on the bed in dead register if it has to be removed at any time during the printing. When setting these screws against the bearers, no force should be employed, merely adjust them to a firm fit against the bearers. These screws eliminate the dangerous practice of inserting leads or strips of card between chase and bearer to counteract chase expansion (Illustration 54).

If the chase has to be removed from the bed after register has been obtained or during the working of a four colour job, take care that only one of these set screws is loosened at a time.

The other acts as a guide when the forme is replaced on the bed, and register is maintained. After the set screws have been adjusted against the bearers, the forme can be relocked, planed down and tested for any "spring" in the usual way.

Illus. 54

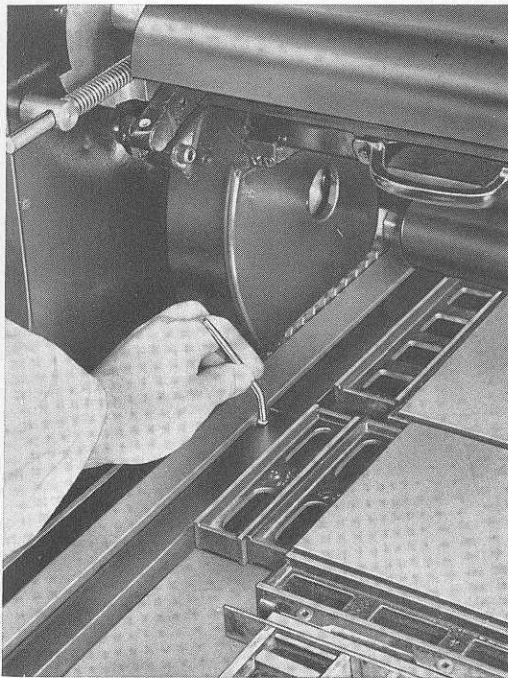

Opinions vary over the make up and selection of the correct cylinder dressing as well as over the positioning and method of make-ready. These differences mainly arise because no set packing can be used for all work. Neither can it be employed on all types of cylinder machines with equal success. We recommend two types of packing; one for type matter and tabular work and one for mixed type and block formes. These packings have been thoroughly tested.

All sheets of the packing should have a 90° fold about $\frac{3}{4}$ " (2 cm) from the end so that they can be easily accurately inserted in the packing clamp. No sheets, whether card or paper, should be inserted loose in the packing. A stock of all sheets cut to size for dressing the cylinder should be kept, so that machine minders have the same material available each time they require it. This achieves a big saving, especially when there is more than one machine.

A. Packing suitable for type matter and tabular work

1. Manila top sheet, pulled tight by draw bar.
2. Manila second sheet, loose end.
3. 6-7 sheets M.F. printing, loose end approx. .002" (40 to 50 g) each, to achieve thickness of packing.
4. Manila to carry make-ready, loose end.
5. Two ivory boards, loose end totalling approx. .018" (0.45 mm) thickness.

B. Packing suitable for large block formes without type

1. Manila top sheet, pulled tight by draw bar.
2. Manila second sheet, loose end.
3. Heidelberg blanket .010" (0.25 mm).
4. 4-5 sheets M. F. printing, loose end approx. .002" (40 to 50 g) each, to achieve thickness of packing.
5. Manila to carry make-ready, loose end.
6. One ivory board, loose end totalling approx. .008" (0.2 mm) thickness.

The sheets of M. F. printing that are positioned on either side of the make-ready should be torn out as required to counteract make-ready added to the cylinder.

We recommend a good quality ivory board for cylinder packing, as sheets will always be found to caliper the same. Boards of uneven thickness cause unnecessary delay in make-ready.

Careful selection of the correct packing for cylinder dressing, and the carrying of adequate, cut to size stock, saves time and money.

Only use the best quality manila, calipering .003" to .004 (0.08 to 0.1 mm), which can be stretched tight without tearing. Always test paper thicknesses with a micrometer, type high gauge or a pair of calipers. The prescribed thickness of the packing together with a sheet of the stock which is to be run should be approx. .047" (1.2 mm).

We recommend that the make-ready be pasted on the centre manila as this practice has been proved the most successful. Manila is smooth and will not allow the make-ready to creep as will a rougher paper.

Adjusting cylinder pressure on bearers

After the forme is placed on the type-bed, the correct cylinder pressure for the forme has to be selected before make-ready is started. Below the cover over the control lever is a lever with an indicator and a scale reading "Light Forme", "Medium" and "Heavy Forme". The pointer should be set against the appropriate position (Illustration 55).

This adjustment controls the amount of pressure between the cylinder and the bearers equally on both sides, and in all three positions the cylinder is firmly on its bearers and rotates at its correct speed relative to the forme.

It is obvious that the cylinder pressure need not be so great for a light forme as for a heavy one.

Correct adjustment of the cylinder pressure saves wear and tear both to machine and blocks, as the load can be lessened for a light forme. Make-ready too is simplified if the correct selection is made.

When cutting, creasing, embossing or printing blocks on the Original Heidelberg Cylinder the greatest amount of cylinder pressure should be applied. Conversely type matter or tabular work is treated as a light or medium forme, and a mixed forme as a heavy one. The size of the forme should also be considered.

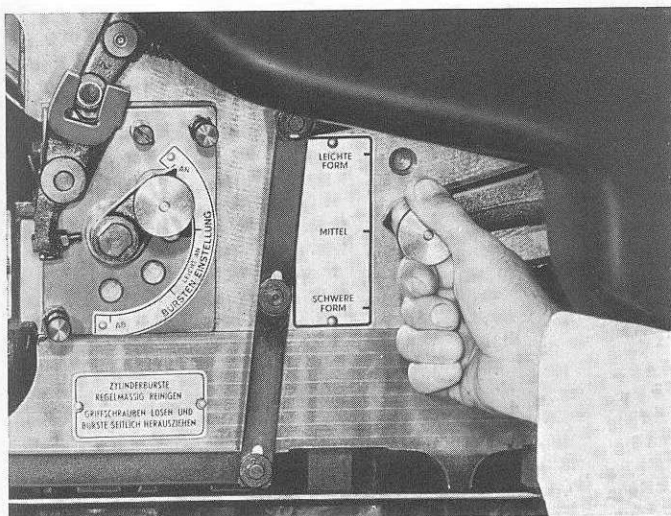

Illus. 55

Clamping the packing

The paper guard over the cylinder should be swung away so that the cylinder is freely accessible. Then the top lid of the duct is laid over the rollers so that the ink does not smear the sheets of the packing. At the same time this lid forms a guard protecting the operator against accidents. The exceptional size of the cylinder considerably facilitates the clamping. The clamp, with the cylinder grippers, is opened by turning a single handwheel, without the use of any tools (Illustration 56). The creased cylinder packing can then be easily inserted, and securely clamped by a few turns of the handwheel.

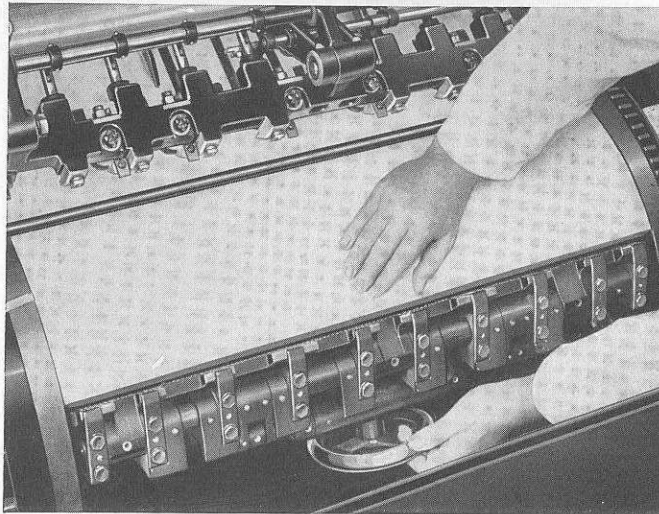

Illus. 56

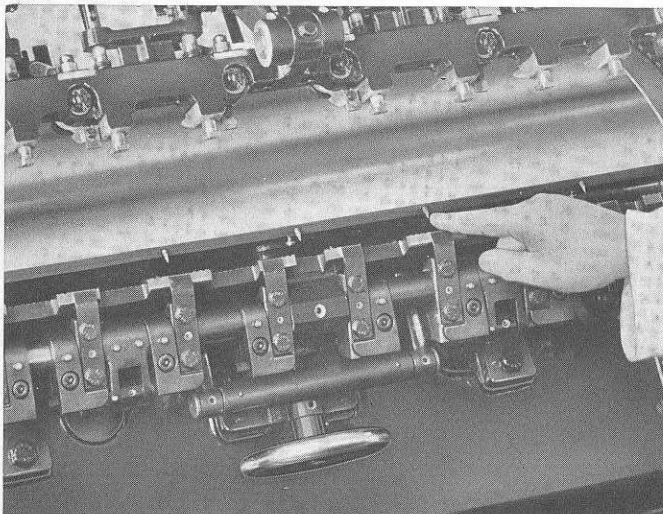

For printers who believe that spikes in the clamp are essential, a set is supplied with the machine and can be screwed into the holes provided (Illustration 57). When the machine is erected the fitter will install them if desired. The blanket supplied with machine is hemmed at one end to take the fixing rod, by which it is anchored to a set of hooks in the clamp. These hooks can also be seen in Illustration 58.

Illus. 57

When the packing is secured in the clamp, the machine should be inched over, by use of the control handle, until the two draw bars are accessible. The blanket is stretched on the lower one and the top sheet of manila on the one above. Both bars can be easily tightened with a tommy bar.

When the packing is to be loosened, a turn of the thumbscrew lifts the ratched and the bar is free (Illustration 58). This thumbscrew also enables the packing to be tightened on the draw bar by hand, with the ratchet disengaged. When hand tight, the ratchet can be engaged and the final tightening done with a tommy bar.

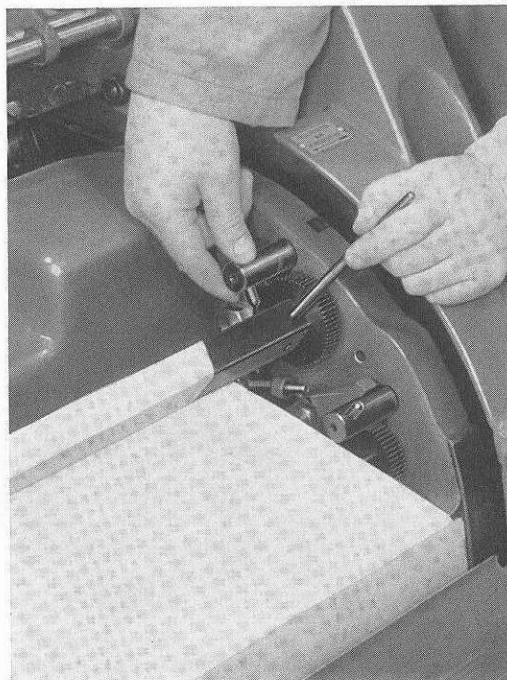

Illus. 58

Make-ready

The enormous cylinder that is entirely free from deflection even when printing the heaviest forme, reduces make-ready to a minimum. Make-ready is confined to correcting inaccuracies in the forme and bringing out the high lights in the half tones. The heavier the forme, the more the Original Heidelberg Cylinder proves its superiority. Whether the printer uses a mechanical or a hand cut overlay, the superiority of the machine shows a reduction in make-ready time. Every tissue is fully effective.

Needling the make-ready sheet

To needle the make-ready sheet, the operator must feed the sheet by hand when the machine has stopped and the feed grippers are in the open position at the front lays. After laying on the sheet, he starts the machine and moves the control lever to "Impression", at the same time turning the speed regulator on the switch-box to speed "2". The cylinder now moves slowly forward, so that the operator can easily move the control lever to "Stop" when the cylinder grippers are immediately beneath the upper edge of the splash guard. In

this position the cylinder is on impression, and the operator can needle the make-ready sheet and finally print it by returning the lever to "Start".

Illus. 59 shows the pasting of the makeready on the manila. The top manila and the blanket are laid back on the roller guard to prevent contact with the rollers. The top lid of the duct is laid back over the rollers to form this guard.

As already mentioned in the chapter on selecting correct cylinder packing, the use of very soft materials should be avoided on the Original Heidelberg Cylinder. It is not necessary to resort to the old trick of using a soft packing to get a heavy forme to print because the machine possesses sufficient impression strength.

When printing blocks alone, the blanket should always be placed in front of the make-ready to provide a small amount of elasticity in the packing. **The Heidelberg blanket is very thin compared to others and made of specially tested materials. Replacements should always be obtained from our agents, as blankets vary widely in quality and suitability. The position of the blanket in the make-ready is of great importance. It should not be directly under the top manila but inserted lower down in the packing after the second manila. This is still considered a hard packing, but it has just the right amount of elasticity when printing.** The make-ready should be pasted on a smooth but tough manila and not on a soft or rough printing type of paper. It is essential that make-ready be pasted to a sheet that does not creep or tear on long runs. We would suggest to any printer who may feel that this is unnecessary advice and who is content to carry on with his usual methods, that he gives our suggestions a trial. The results will convince him that our exhaustive experiments have not been in vain.

Because of its heavy design, the Original Heidelberg Cylinder has many advantages over any other machine and it is to the printer's own advantage to follow our suggestions concerning packing, make-ready, forme adjustment and the height of half tone blocks, even if he has to break with tradition to do so.

The printer must know and understand his Original Heidelberg Cylinder if he is to produce the highest class of printing.

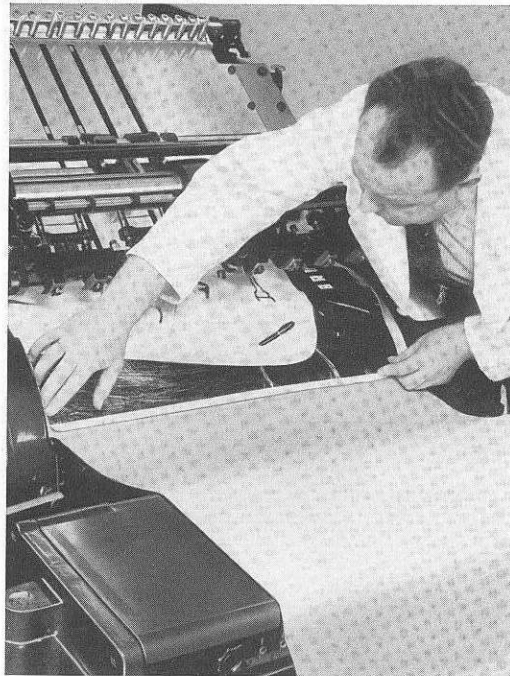

Illus. 59

Loading the feed table

Before loading the feed table, the paper should be fanned out to ensure that it will not adhere at the cut edges. With any automatic feeder fanning out the sheets greatly assists a trouble free run (Illustration 60).

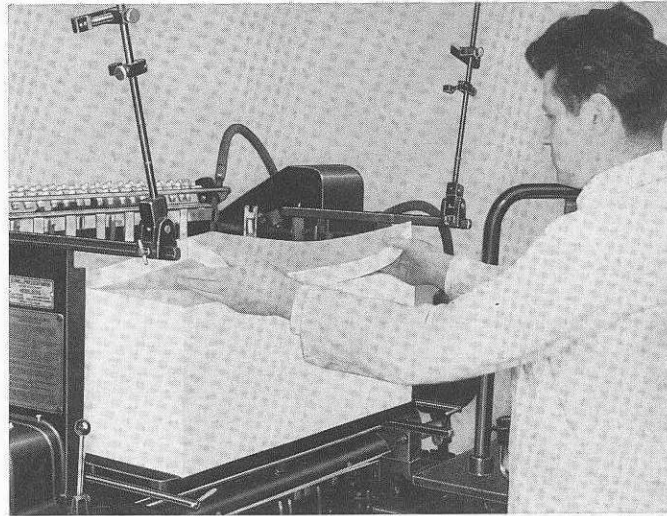

Illus. 60

Drop the feed table to its lowest position. The standards should be in their correct positions, having been set when the forme was put on the machine. To lower the feed table, first disengage

handwheel by the white ball handle on top of the guard. This handle may be used as a brake for lowering the table by pulling it further to the left. The other white handle on the side of the guard serves to engage or disengage the pile transport during the run (Illustration 61).

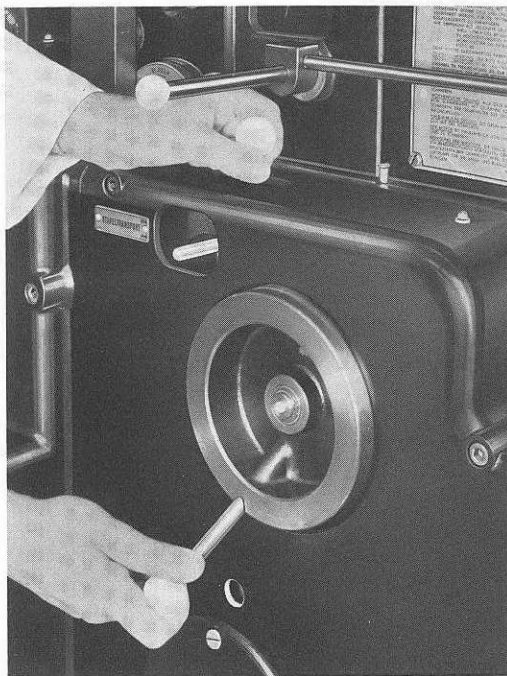

After loading the feed table it should be raised by the handwheel until the top sheet reaches the sucker bar. When board is being printed the top sheet should be touching the sucker bar. Of course, first check that the sucker bar is in its lowest position. With thick paper the clearance between sucker bar and the top sheet should be $\frac{3}{16}$ " (5 mm) and with air mail the clearance should be $\frac{3}{8}$ " (10 mm). Any suckers which extend over the edge of the sheet should be turned off.

With the Original Heidelberg Cylinder a pre-loading device is supplied which enables the machine-minder to insert a new feed pile during the run. The idle time of the machine during the change over takes only about 1 minute (further details can be found on pages 122-124).

Illus. 61

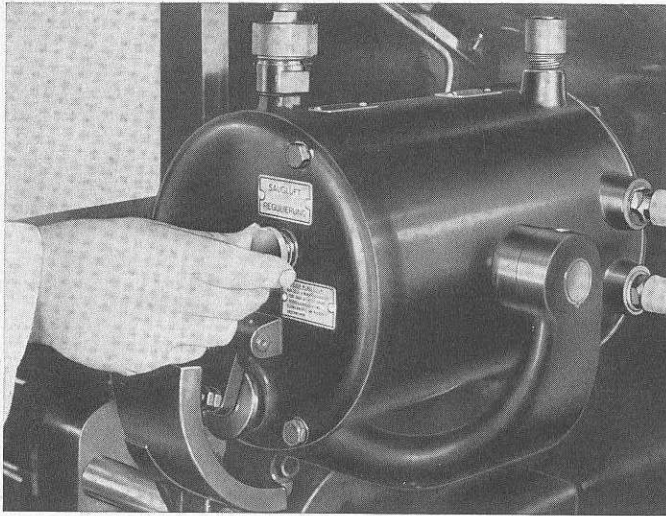

Regulation of suction

The strength of the suction can be regulated by a valve on the air pump on the driving side of the machine (see instruction plate).

The suction must be regulated to suit the weight of the stock.

Illus. 62

Illus. 63

Regulation of sucker bar tilt

The mechanism for adjusting the amount of tilt of the sucker bar is to be found on the frame of the feeder on the operating side. Tilt can be regulated by a micrometer adjustment, the setting is by means of a screw and a scale. Generally speaking, the thinner the paper the more tilt is required on the sucker bar. The two extreme ends of the scale read 'Thin Paper' and 'Cardboard' and between these limits the correct angle of tilt has to be found. It is possible that both thin paper and board may be lifted successfully with a different angle of tilt from that prescribed; weight and density of the material as well as whether it is wavy or lies flat being factors that have to be considered (Illustration 63).

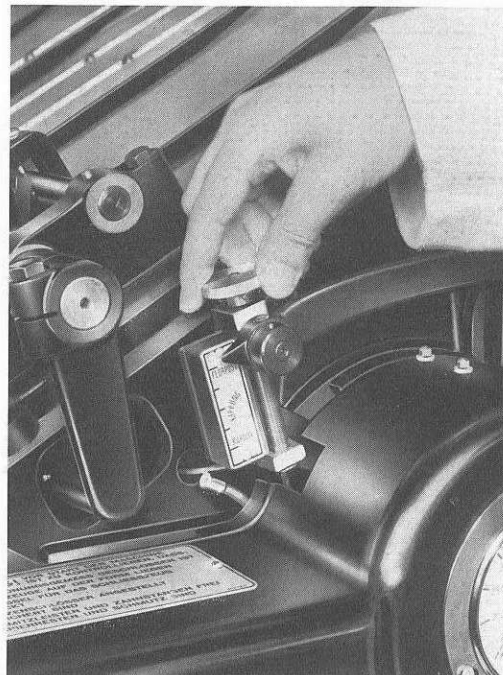

Sheet separation

The main method of separating the top sheet from the rest of the pile is by a blast of air from the front of the pile. The **strength** of the blast air is regulated by a spring-loaded valve located on the air pump (Illustration 64). The **amount** of the blast air can be regulated by a tap on the big cover on the driving side of the machine. Full air is supplied when the tap lies in the direction of the pipe (Illustration 65).

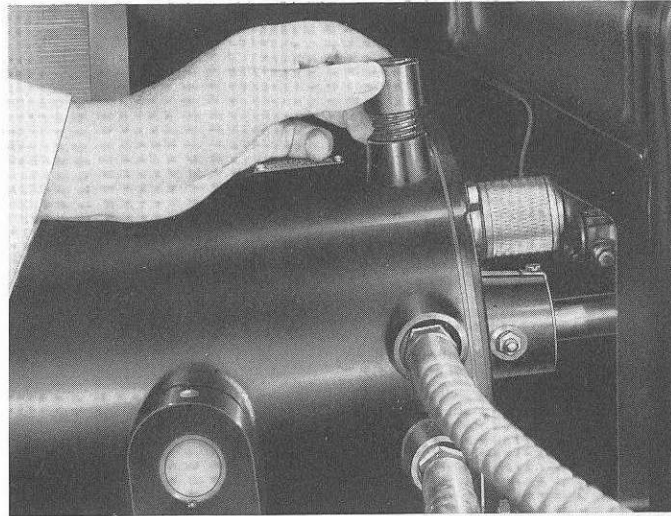

Illus. 64

The effect of the blast of air is to separate the top sheet of the pile after it has been lifted clear by the suckers. The air should blow the entire length of the sheet so that the end flaps when lifted. Tinner papers require less blast than thicker ones.

The height of the blowers can be adjusted by a small lever and scale on the operator's side. With thin papers (airmail, onionskin) the indicator should be positioned to "higher", with normal papers in the middle, and with card to "lower" (Illustration 66).

Illus. 65



Illus. 66

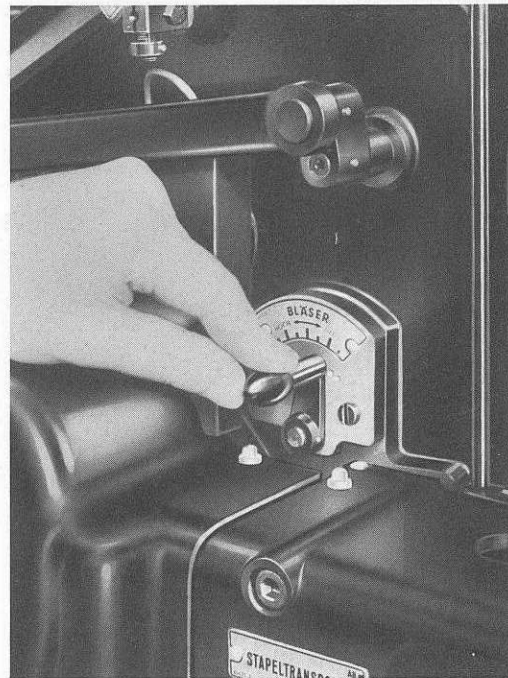

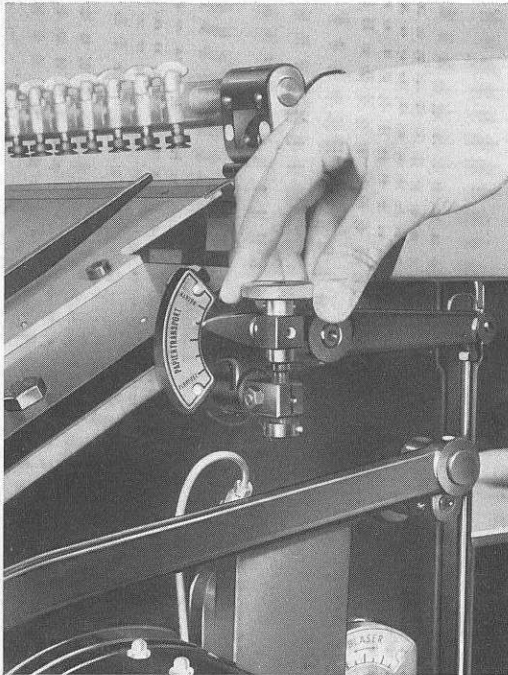

Regulating rate of lift of the feed table

Above and to the right of tilt regulator is a similar device for regulating the rate at which the feed table is raised. The two extreme markings on the scale read "Tissue Papers" and "Cardboard" and the rate of the lift of the feed table can be increased or decreased between the two extremes (Illustration 67).

Illus. 67

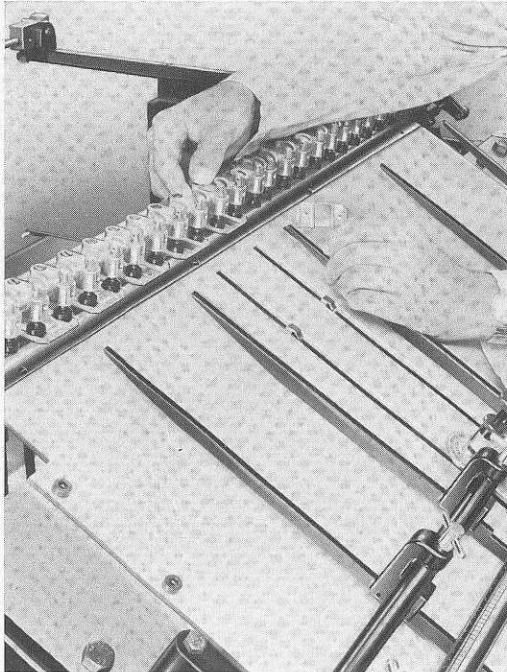

Use of tissue slides

Included with the accessories of the machine are tissue slides. These slides have extra small apertures to facilitate picking up onion skin, airmail etc. The slides fit into position on the suckers from the rear (Illustration 68), and have a small aperture which is offset toward the front. This enables the sheet to be picked up closer to the front edge, and reduces the possibility of picking up two sheets. The suckers not in use must be closed.

The set consists of 12 slides which fit under 2 metal suckers. The 12 slides will be sufficient for the whole width of the sucker bar. Small size ranges will require slides according to the width of the stock.

Illus. 68

Also included in the accessories is a narrow metal strip to be used when feeding thin papers. It is snapped on to the height control bar of the feed table by three spring clips as shown on illustration 69. The flat surface of this metal strip will prevent the height control bar from pressing into the feed pile. When using the metal strip it is recommended that the lever for the feed lift should not be put on "Thin Paper", but more in the direction of "Cardboard".

The metal strip can also be used for all thin papers which do not lie flat and level at the front edge.

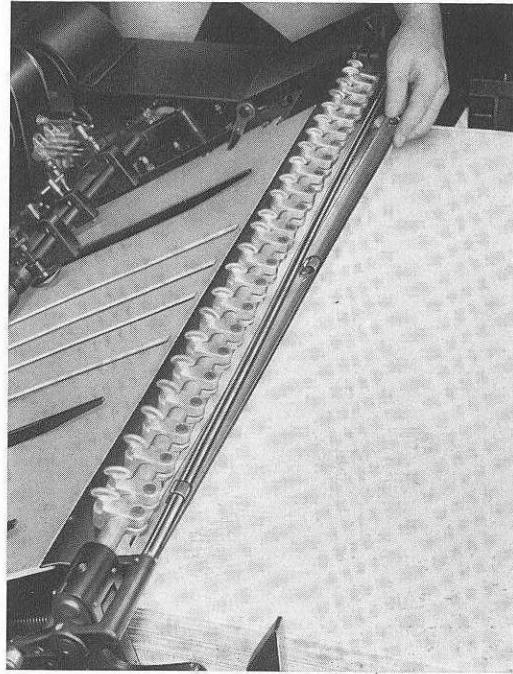

Illus. 69

Use of rubber suckers

To increase the effectiveness of the suction on heavy papers and boards an assortment of rubber discs are supplied with the machine. These discs slip over the head of the suckers and are held in place by fitting into a slot on the sucker. According to the weight of stock to be lifted, so more or less rubber suckers are fitted. Suckers which are not used should be closed (Illustration 70).

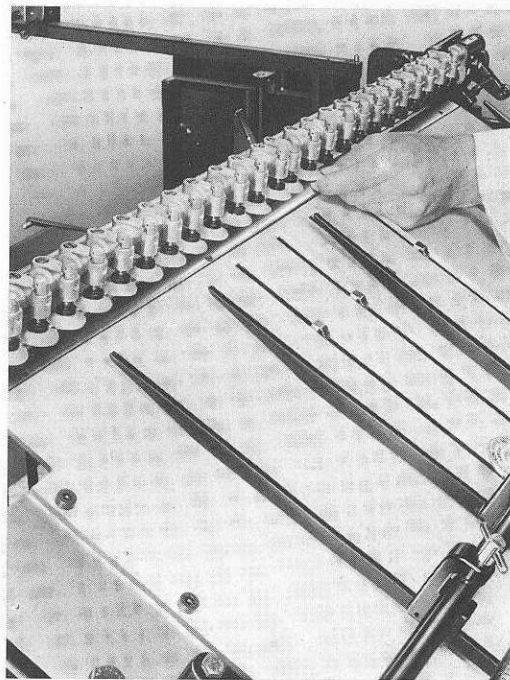

Illus. 70

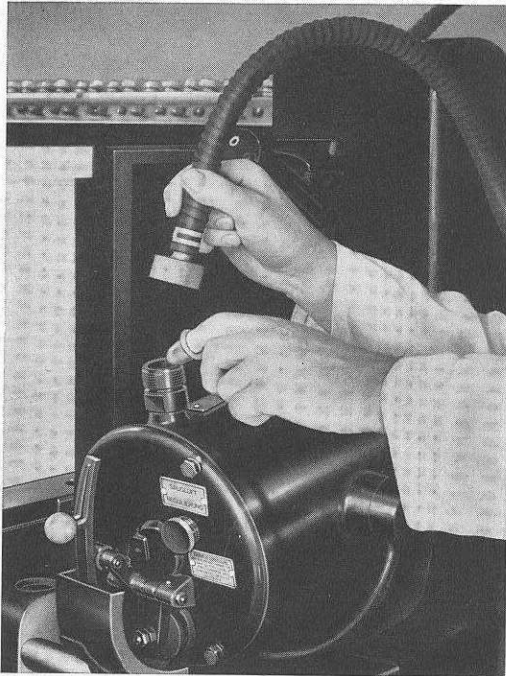

If heavy stock or board is not lifted despite the use of rubber discs the reason can often be found in the fact that the paper dust filter located in the hose connection has to be cleaned. When running papers which develop a strong dust this filter may have to be cleaned **daily**.

Illustration 71 shows how the filter is taken out after the hose coupling with its screw connection is screwed off the air pump. The paper dust filter is washed in benzene or forme cleaning fluid. Do not use roller washing fluid as it contains oil.

Illus. 71

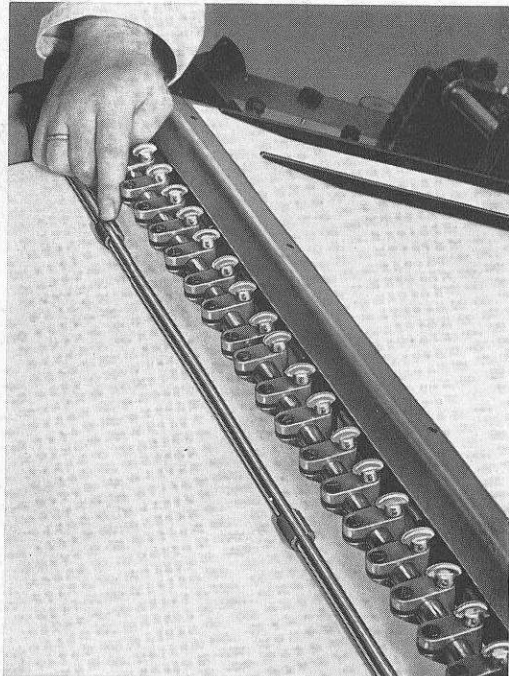

Use of rubber sleeves on the feed control bar

A rod situated behind the sucker bar, which makes contact with the top sheet of the pile every time the suckers pick up a sheet, controls the rate of lift of the feed table. The rod follows the action of the sucker bar and detects by uniform movement the height of the pile. It may happen that when printing, for example, the second working of a four colour job that this detector rod contacts and marks the freshly printed part of the sheet. To avoid this, fix two rubber sleeves on to the bar, placing them so that they come in contact with the margin or other convenient print free space. The rubber sleeves are included in the accessories with the machine (Illustration 72).

Illus. 72

Use of tripping springs

The separation of the sheets is also assisted by a series of tripping springs set in to the front edge of the pile. These springs are slotted and can be fixed at any height after loosening the holding screws.

The bent over ends of the springs point towards the front edge of the pile and help to separate any sheets which hang together when lifted by the sucker bar. All springs must be set to one height. Normally the upper edge of the springs should be approx. $\frac{3}{8}$ " (10 mm) below the top of the frame of the blower. Two kinds of tripping springs are supplied with the machine. Those with a right angled claw at the top are used for thinner papers. For thicker papers, which separate more easily owing to their weight, springs with the obtuse angled claw should be used (Illustration 73).

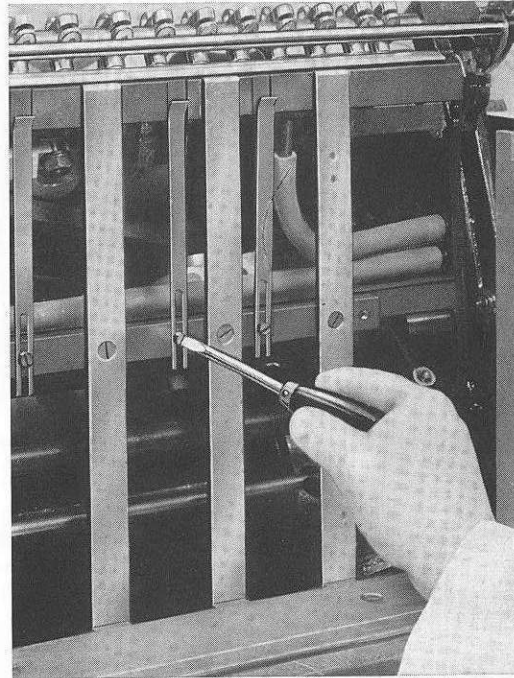

Illus. 73

With cards, it is advisable to use the flat springs which are mounted for use on the side of the pile. On each end of the blower there are two slots for fixing these flat springs, while for the small size, the holders provided should be used and fixed in any position on the blower (Illustration 74).

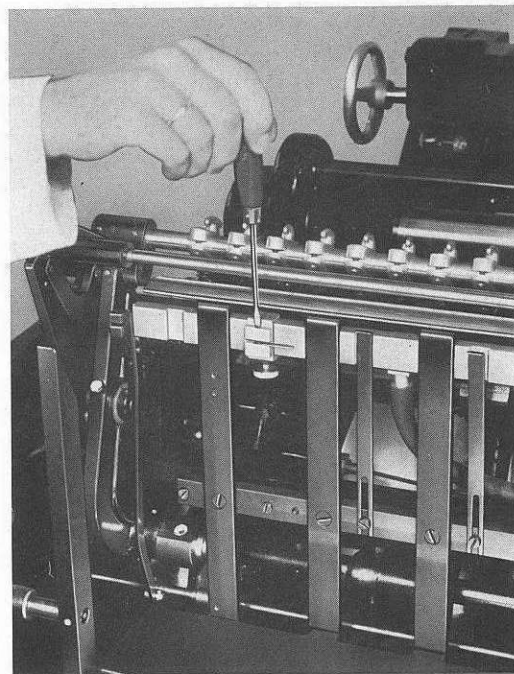

Illus. 74

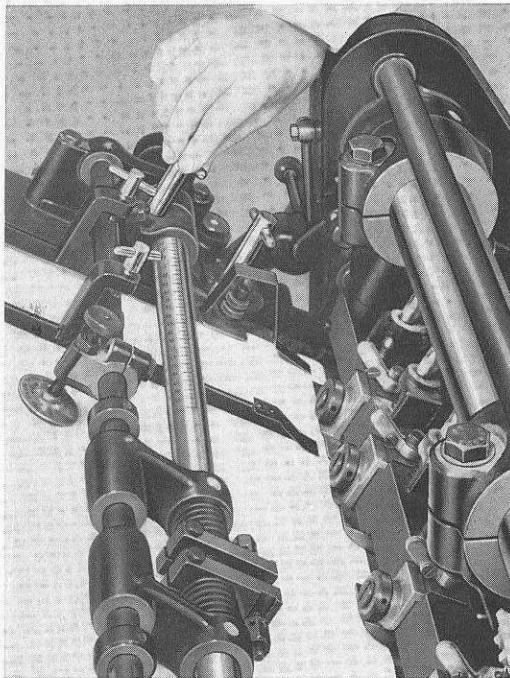

Illus. 75

Setting the side lays

The reading from the chase scale, obtained by positioning a sheet on the forme, is used for setting the side lay, there being a corresponding scale on the side lay spindle. For lateral adjustment, loosen the thumbscrew on the spindle and slide the lay to the required position, then tighten thumbscrew. In registering the sheet, the side lay should move it laterally between $\frac{5}{32}$ " to $\frac{1}{4}$ " (4 to 6 mm). This movement is allowed for when setting the side lay (Illustration 75).

Illus. 76

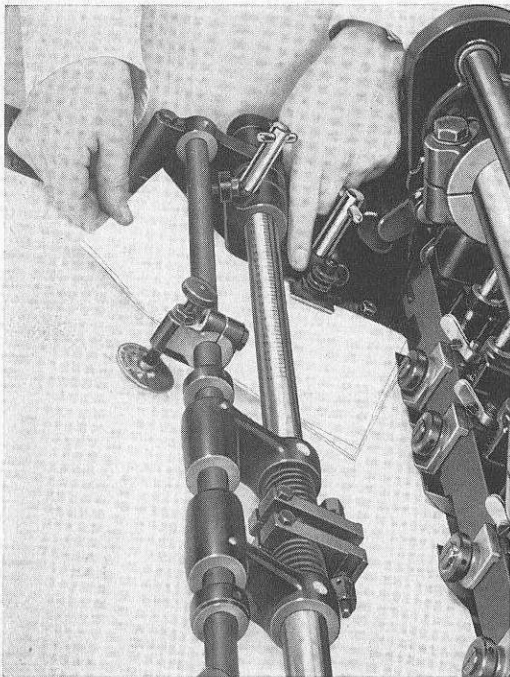

Adjusting the cover plate

The side lay is equipped with a cover plate which can be adjusted to the thickness of the stock being printed. This cover plate prevents the sheet from rolling up at the lay edge when being registered and should be adjusted to three thicknesses of the stock being used. First loosen the locking nut of the micrometer adjuster, not forgetting to tighten it again after adjustment. As the feed table grippers carry the sheet into the side lay, the cover plate lifts to avoid contact with the sheet.

When printing a full out sheet one side lay must be removed from the machine in case it should interfere with the movement of the sheet. For a smaller sheet, both side lays can remain on the machine. The side lay on the operator's side should normally be used as it is more conveniently reached (Illustration 76).

Micrometer adjustment of side-lay

For absolute register the side lay is adjusted by a micrometer. Loosen the thumbscrew which holds the actual lay to the bracket, make the necessary adjustments by means of the screw wheel, then tighten the thumbscrew again. A scale is provided for visual adjustment, located on the lay the base of the thumbscrew (Illustration 77). When preparing the machine for a new job take care that the side lay is in its center position.

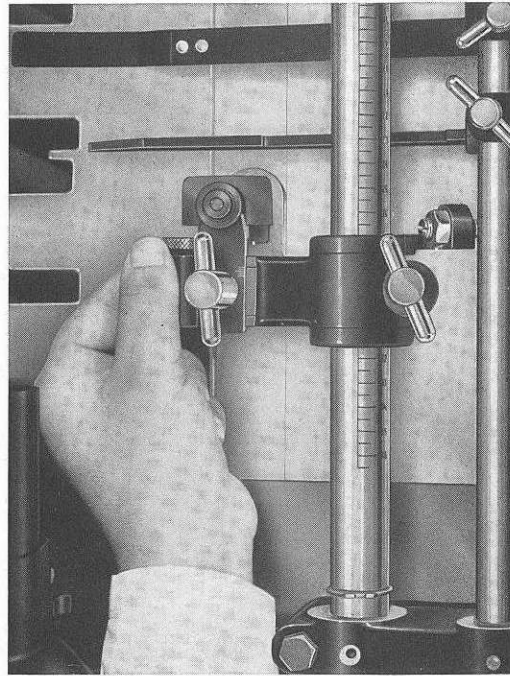

Illus. 77

Adjustment of front lays

Six front lays are permanently mounted on the swinging gripper bar and have a micrometer adjustment of $\frac{5}{64}$ " (2 mm). If the lays are screwed right out towards the feed table, after loosening the locking device, the gripper bite is $\frac{5}{16}$ " (8 mm). When screwed fully in the opposite directions, the gripper bite is increased to $\frac{3}{8}$ " (10 mm) (Illus. 78).

Only two front lays are employed at a time. The selection of the two to be used is made when the forme is positioned in the chase.

Four front lays are used only when printing two-up (2 for each sheet).

When imposing, allow for a $\frac{25}{64}$ " (9 mm) grip so that adjustment can be made in either direction. Do not forget the front lays not in use should be screwed right in so that they do not make contact with the sheet and upset register.

Illus. 78

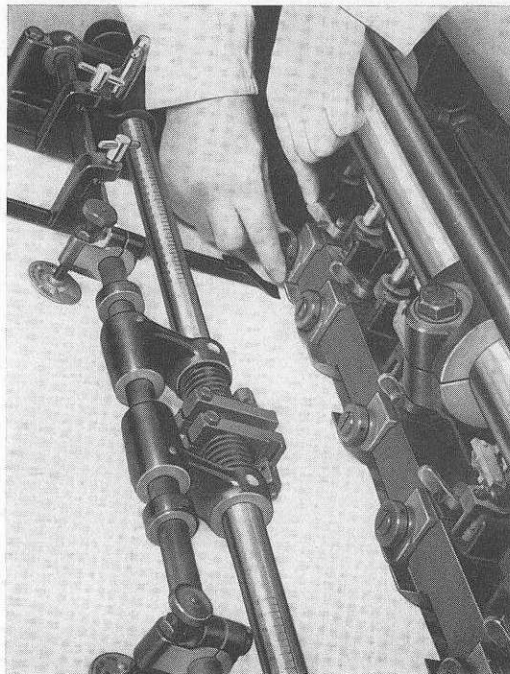

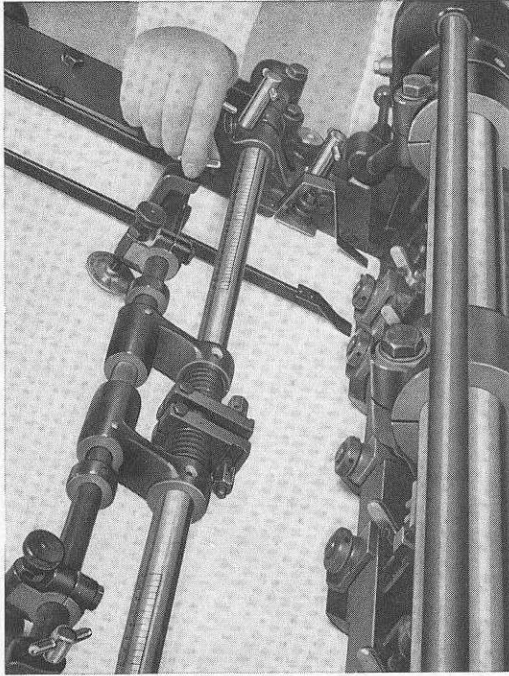

Use of smoothers

If the sheet tends to roll up or flap at the edges during its travel down the feed board, especially at high speed, smoothers can be mounted on the bar above the side lay spindle (Illustration 79). Two short smoothers are designed to fit up to and over the side lays to keep the corner of the sheet flat (Illustration 79).

Illus. 79

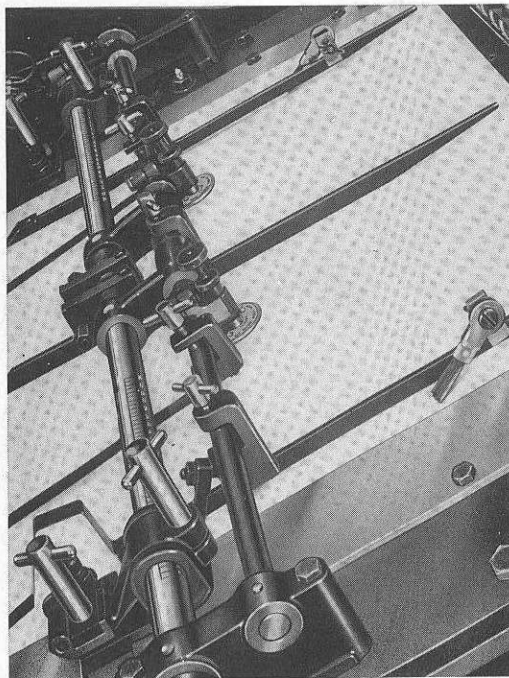

Use of sheet brakes

We also supply with the accessories for the machine two brackets with steel bands which are to be used as sheet brakes on the feed table. When the machine is running at high speed the sheet may jump at the front lays and cause bad register. If the two brackets with the steel bands are fixed to the same bar as the smoothers shown on illustration 79 the sheet will be slowed down and the speed at which it arrives at the front lays after having been released from the feed table grippers is decreased.

When running jobs which demand an absolutely perfect register at very high speed it is recommended that the brake brushes be used. These brake brushes belong to the standard equipment of the machine and can be screwed on to the sheet smoothers. The brushes act as additional sheet brakes on the feed board (Illustration 80).

Illus. 80

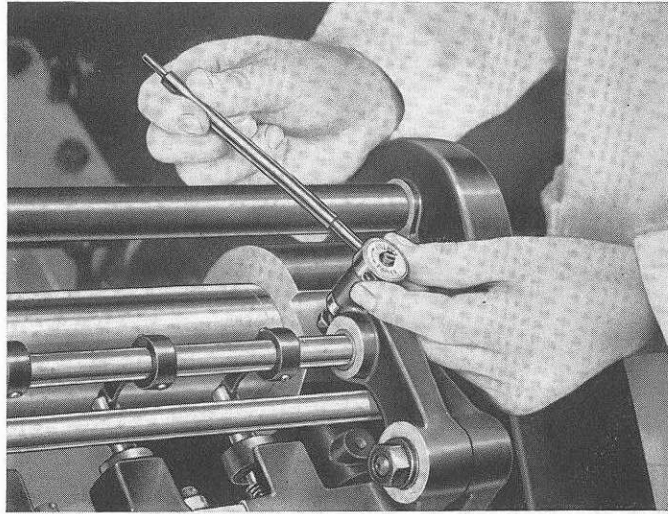

Illus. 81

Adjusting the swinging grippers

The swinging grippers are provided on the drive side and operating side with an adjusting screw. This enables the machine-minder to enlarge the clearance between the gripper shoes and the aluminium feed board in order to avoid register troubles with thick cardboard or wavy stock. The adjustment of these screws is carried out with a tommy bar. When running heavy cardboards which jam in the lays during the registering process, the adjusting screws should be set on "Cardboard". However, when the machine is used again for runs on normal paper or thinner cardboard, the adjusting screws have to be reset on "Paper". This is necessary because otherwise there would be too much clearance between the gripper shoes and the feed board, which might result in register difficulties when running normal paper stock.

It should be especially emphasized that the normal clearance between the gripper shoes and the feed

board is in most cases quite sufficient. This is proved by the many thousands of Original Heidelberg Cylinder already delivered so far. The adjustment was primarily introduced because of the increasing number of Original Heidelberg Cylinders being utilized as cutting and creasing presses for cardboard work.

Adjusting sheet calipers on the feed board

If, by chance, two sheets are fed into the machine, no damage will result as long as it is thin stock. If heavier sheets are double fed, the forme could be damaged. To prevent this, two sheet calipers are mounted on the shaft over the aluminium feed board.

Sheet calipers are most effective on heavy paper stock and cardboard. Take two sheets, loosen the lock nuts on each of the sheet calipers and turn the calipers downward so movement of the two

sheets beneath the calipers is restricted (Illustration 82).

After correct position is found, the lock nuts are secured to insure a firm hold of the calipers during operation.

In case two sheets are fed, the calipers will prevent them from continuing to the front guides and transfer grippers. Sheets not reaching the transfer grippers will cause the machine to stop automatically.

Sheet calipers will also function when a sheet with curled up corners is fed. Both sheet calipers can be adjusted to paper size by loosening the screws and moving them on the shaft. The shaft is provided with two stop rings to prevent the sheet calipers from being set over the travelling feed grippers.

If the calipers are adjusted too low, the machine will stop unnecessarily. When adjusted too high, they cannot perform their function.

We recommend placing sheet smoothers adjacent to the sheet calipers. This will help to keep the sheet down when travelling over the feed board.

Operation of automatic cut-out

If the feed table grippers fail to deliver a sheet to the lays, or should there be a feed fault of any kind, the machine is immediately stopped by a mechanical cut-out device. There are two automatic cut-outs mounted on the swinging gripper bar and operated by two control rods.

They can be made inoperative by pushing the flaps downwards (Illustration 83). The flaps bear a name plate "CONTROL DISCONNECTED".

With a small sheet, only one of the two cut-outs need be used, the second one being rendered inoperative. With a large sheet stretching over the two cut-outs, both should be operative. As a

Illus. 82

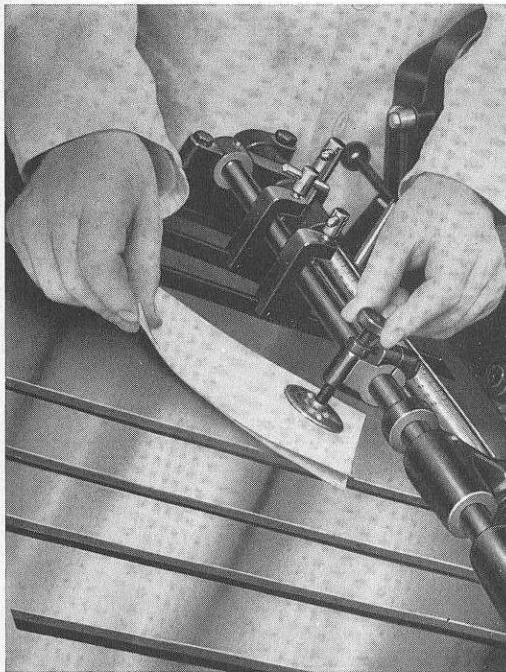

Illus. 83

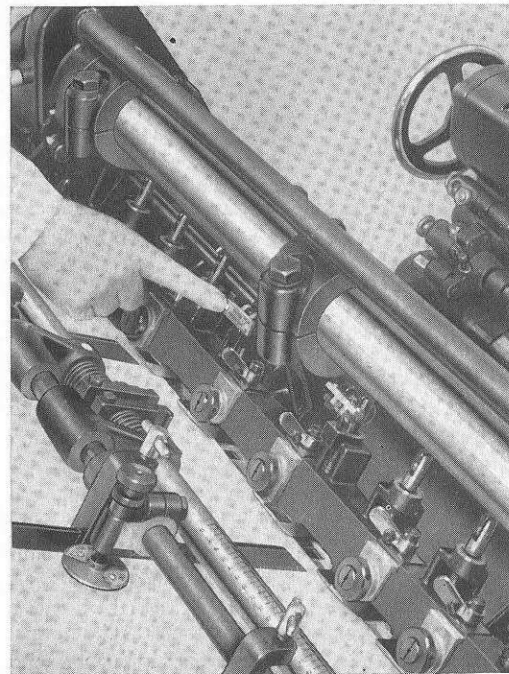

miss can only be made on the cylinder when the control lever is at "IMPRESSION" the automatic cut-outs are only operative when the control lever is in this position. The automatic cut-out is controlled by the control lever and is inoperative when the lever is at "RUN" or "PAPER". At a feed fault the cut-out device comes into action immediately disengaging impression and stopping the machine.

The control rods of the cut-out must drop easily and to eliminate any chance of them sticking it is advisable from time to time, to clean them with white spirit from the container of the roller washing device. As this fluid is of an oily nature, it not only cleans but lubricates the rods. Do not use oil on the rods as they are likely to collect dust and become sticky, the free movement of the rods would thus be impaired.

Both cut-outs work independently of one another so that when printing two up the machine will stop if there is a feed fault on either side.

Cylinder brush adjustment

The cylinder brush performs the important tasks of holding the sheet flat against the cylinder and

preventing paper or spray dust from falling on the forme.

The adjustment of the brush against the cylinder is done by a hand control lever (Illustration 84). In the handle is a plunger which, when pulled out, allows the lever to be moved to any of four positions according to the pressure required to hold the sheet accurately against the cylinder.

The brush must be used for all register work also for multi colour half tone work. When printing, for example, the second colour of a four colour process job and the ink is not quite dry, the pressure of the brush can be eased to avoid marking, but for most jobs the brush can be fully employed. The brush comes in contact with the sheet before impression begins so that the sheet cannot possibly sag and touch the forme. If the bristles should become worn after long service the brush must be reset with the aid of the adjusting screw shown on Illustration 85. All one has to do is to loosen the counter nut and screw out the adjusting screw slightly. This readjustment should only be carried out when the brush is in contact with the impression cylinder. To check the correct position of the brush, insert two strips of paper between the brush and the top sheet of the packing.

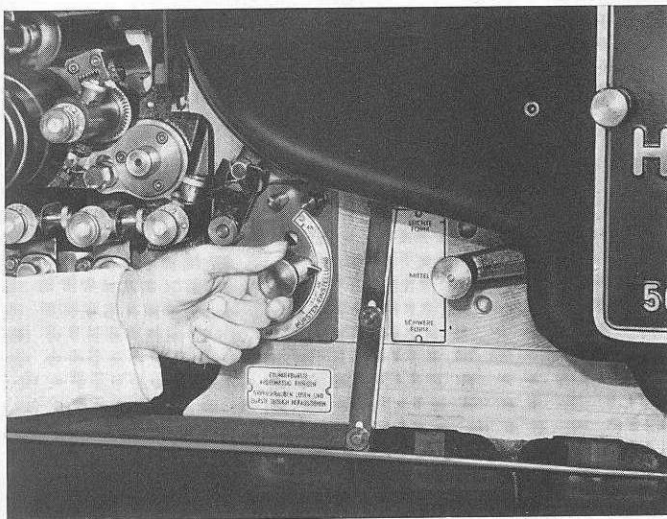

Illus. 84

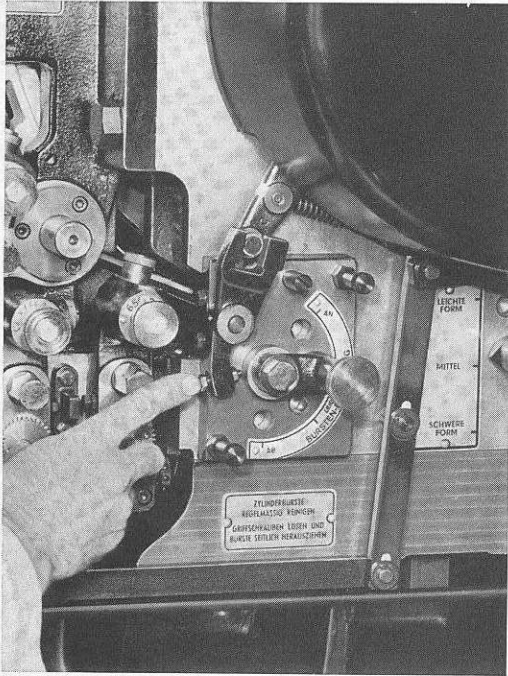

Illus. 85

The brush pressure against the cylinder is adjusted correctly when these paper strips can be drawn out from under the brush without being too tightly or loosely pressed against the cylinder. During this adjustment the operating lever must be in the position "IMPRESSION" while the main switch of the control box should be set on "O". After the adjustment of the brush, the adjusting screw must be secured again with the counter nut. If the screw is not set properly the brush will press too tightly or too loosely against the impression cylinder which might lead to register difficulties.

Fitting new brush

When, after long service, the bristles become too worn to be effective, they must be renewed. An exchange service exists for this and our agents can supply a new brush complete with the fixing plate. The old one, complete with fixing plate will be taken back in part exchange after the new one has been delivered.

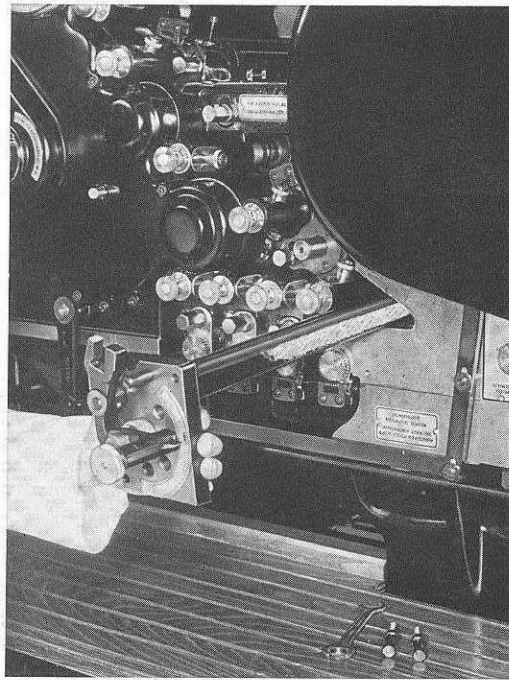

Illus. 86

Cleaning the brush

The brush must be cleaned periodically; this is quite a simple operation. Unscrew the two holding bolts in the brush plate and withdraw the brush (Illustration 86).

Before withdrawing the brush, the impression cylinder has to be turned till the gear segments show upwards and the hollow part of the cylinder is above the brush.

The brush itself and the dust trough underneath it have to be cleaned thoroughly and the bristles washed out in benzene.

When replacing the cleaned brush make sure that the actuating roller is fitted into the slot on the brush spindle. It is recommended to put a drop of oil on to the end of the brush rod before replacing the brush after cleaning.

When using the powder sprayer the brush has to be cleaned daily.

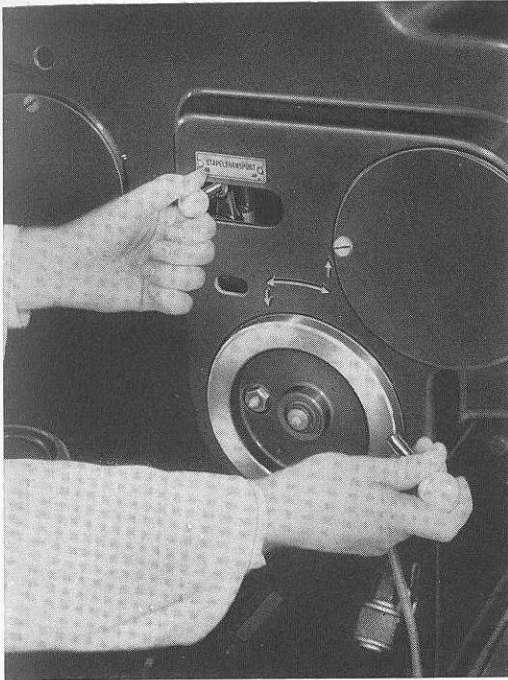

Illus. 87

Adjusting the delivery table

Raise the empty delivery table into highest position by pulling the white knob as far as possible to the left (Illustration 87). Then engage white knob in "ON" position so that the lowering mechanism is operational. If the paper stock transport is tripped during the run put the white knob on "OFF" position. The engaging of the white knob in "ON" position should be delayed until sheets have been piled on the table to a height of about $\frac{3}{8}$ " (1 cm).

This avoids the possibility of the first sheets slipping under the back stops on the table where they might not have made contact. There is no separate adjustment for controlling the rate that the table is lowered and it moves in conjunction with the feed table. Adjusting the rate of rise of the feed table automatically adjusts the rate at which the delivery table is lowered.

Illus. 88

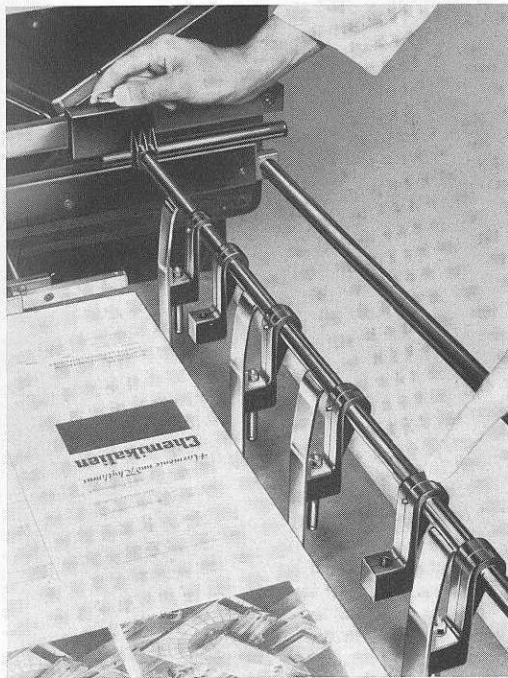

The rear standards of the delivery table are mounted on a bar which can be moved backward or forwards on two runners, after first loosening the two set screws.

The rear standards can be inserted into each of the six holders, depending on the paper size (Illustration 88).

To adjust the rear standards and side guides, run a sheet through the machine and bring it slowly out on to the carrier. As soon as the sheet falls on the delivery table, hold it fast and adjust the stops around it.

The rear sheet stops are easy removable (Illustration 89). When running jobs two-up it is recommended that four rear stops be used.

The delivery carriage bars are telescopic and can be shortened to 12" (30 cm). This provision allows more time for the sheets to fall, especially when running smaller sizes. Since small sheets do not slide over the full length of the delivery carriage bars, the danger of smearing is largely eliminated. The adjusting screws are on the lower side of the telescopic delivery bars (Illustration 90).

Especially when running thin paper stock such as cellophane etc. which is rather "flappy" by nature the flat delivery carriage bars have proved to be of great advantage. The sheets have a broader resting surface during the delivery process and will not sag between the bars.

The delivery carriage bars should be cleaned once a week in order to remove the powder and liquid spray residue. When running very thin and "flappy" paper stock it is also advisable to adjust the length of the delivery carriage bars in an irregular manner. This will give thin paper sheets a better stability. If, for example, the corners of a sheet curl upward during the delivery process it is recommended to shorten the outer delivery carriage bars so that the corners of the sheet are held down by the air blast of the delivery blowers.



Illus. 89

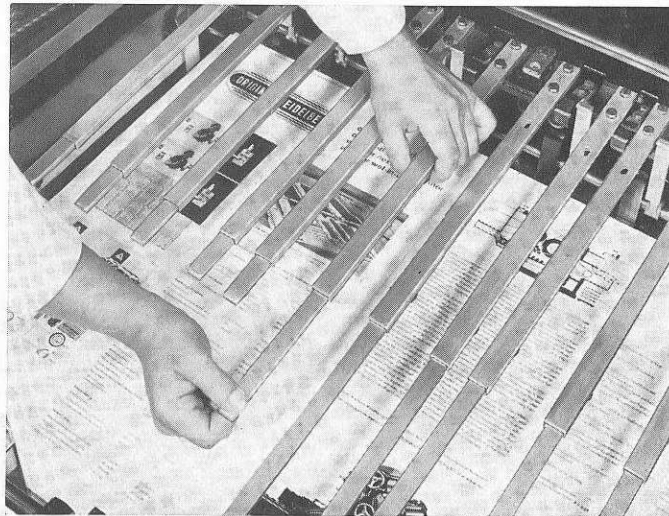

Illus. 90

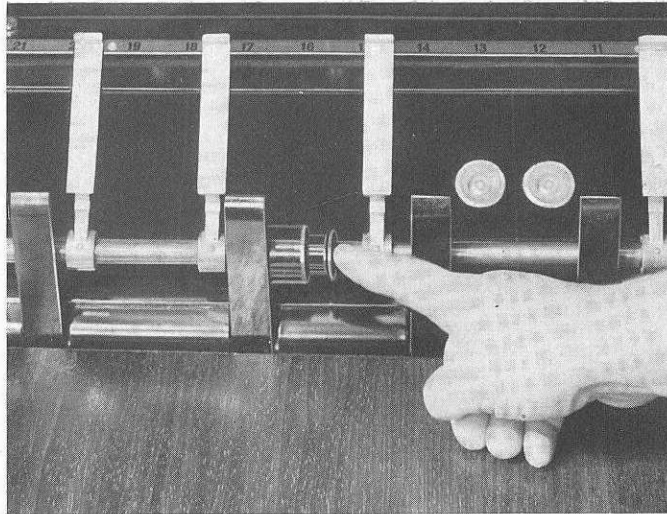

Illus. 91

The side and front guides can be adjusted, and serve as moving sheet guides. For actuating the moving front guides a small roll behind the front guides must be slid sideways (Illustration 91).

Illus. 92

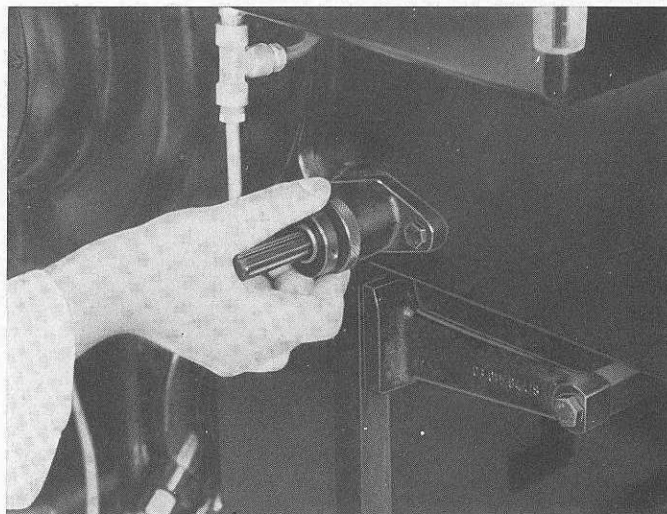

The locking wheels on the outside of the side-frames of the delivery must be loosened (Illustration 92) in order to put the side guides into operation.

After loosening the two stop screws the side guides can be moved and adjusted to the paper size (Illustration 93).

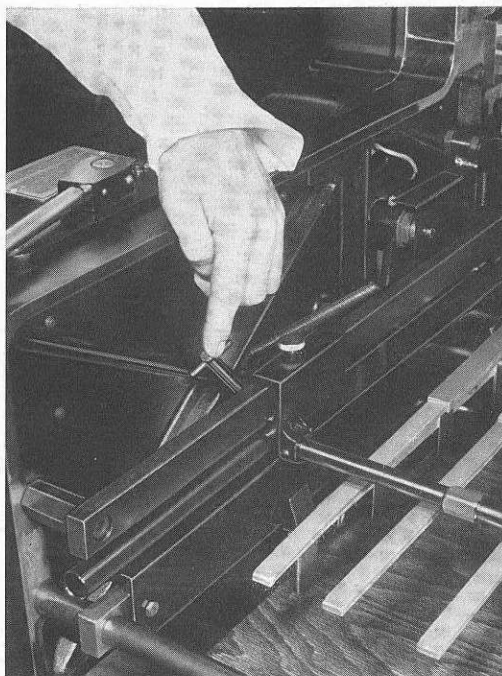

Illus. 93

Adjustments on chain delivery system

After impression, the cylinder grippers transfer the sheet to the chain delivery grippers, which move continuously and uniformly with the cylinder, therefore, there is no undue pull to upset the register.

The sheet is turned, printed side up, by the chain delivery system and at the point of turning, the sheet is supported by a series of star wheels. These star wheels can be moved laterally on their spindles and the spindles themselves can be moved to alternative positions on the chain (Illustration 94).

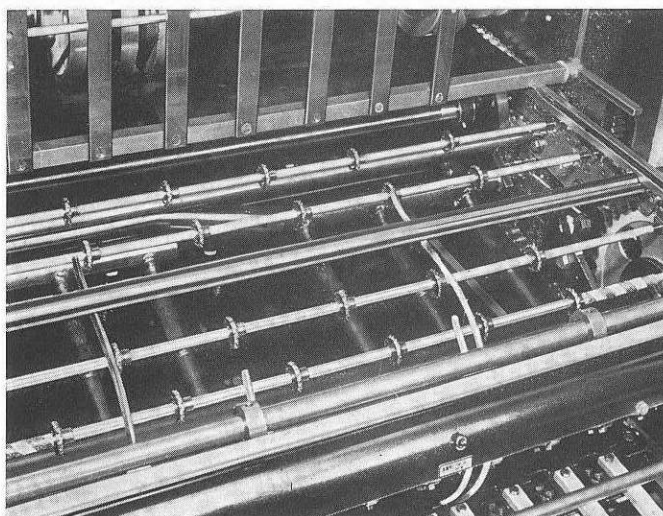

Illus. 94

On the first spindle after the gripper, the star wheels have been replaced by $\frac{5}{32}$ " (4 mm) wide rollers. The first spindle after the gripper takes the initial and the greatest strain as the sheet is turned over, and the rollers, being smooth, do not press into the sheet. If the first spindles were equipped with star wheels there is a possibility that their points would mark the printed sheet, especially if it contained a large solid printed with a sticky ink.

One end of the spindle mounting the star wheels is spring loaded. To remove, push spindle against the spring and slip the other end from its socket. To insert, reverse the process, the spring loaded and being inserted first (Illustration 95).

Care must be taken that both ends of the spindles are properly housed in the two opposite sockets.

The fact that the star wheels can be moved to any position on the spindle and the position of the spindles can be varied, makes it possible for the star wheels to be adjusted so that they contact a print-free spot.

If there are no print-free spots at all and some star wheels mark the printed sheet one can take them off and replace them by sandpaper sleeves (Illustration 96).

The printed sheet falls approx. 4" (10 cm) from the carriage to the top sheet of the pile. This drop was designed purposely to create a temporary air cushion between the printed sheets to assist in avoidance of set-off. However, as different kinds of stock vary in weight, it is necessary to control the speed at which the sheet drops to the pile.

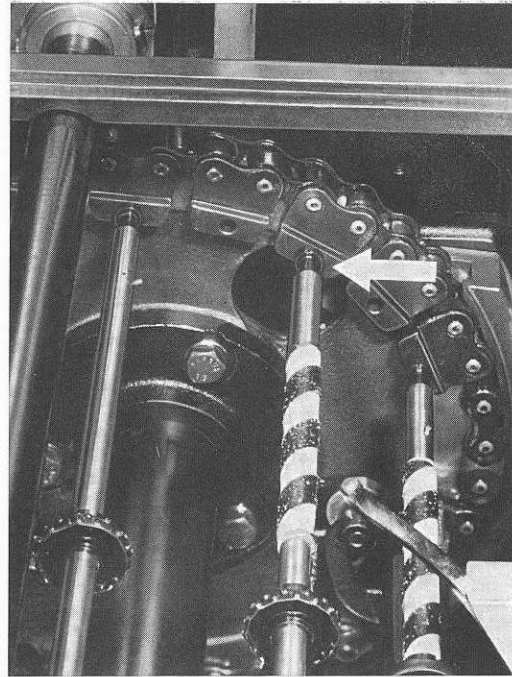

Illus. 95

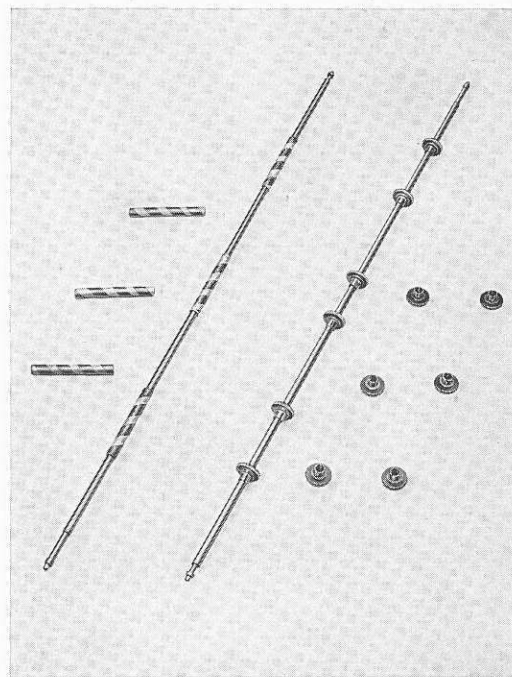

Illus. 96

Air Blast for the sheet delivery

An air blast pipe is fixed permanently at the delivery over the grip edge of the sheet. Its purpose is to create an air cushion between the top of the delivery pile and the sheet which is being delivered. The amount of blast from this pipe is regulated by an adjusting velvet situated on the pipe itself (Illustration 97). The air blast pipe is provided with a pin by means of which the pipe may be turned if the direction of the air blast requires an alteration.

This pin shows also the direction of the blast. The air blast supporting the delivery of the sheets on the delivery carriage and also keeping them flat-

tened at the higher speeds can be adjusted by a set screw located on the operator's side to the right of the door at the control lever guard (Illustration 98).

The regulation is made between the two positions "ON — OFF" on the operation plate. In most cases the full amount of air blast should be used; only when printing thin papers or onion skin in smaller sizes should it be reduced a little. The air blast of the two outer air blast pipes on either side of the six pipes in the delivery can be regulated by means of a velvet independently of the entire amount of air blast.

Illus. 97

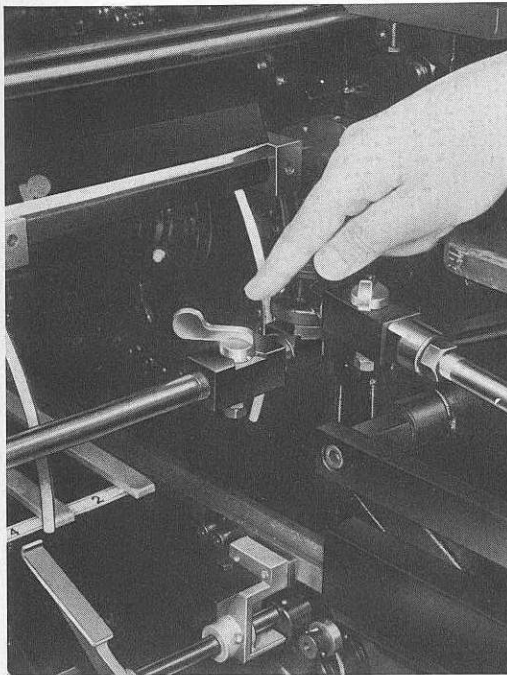

Illus. 98



Removing the wheeled delivery table

The machine is delivered equipped with two delivery tables, mounted on casters, which enable them to be wheeled away. The casters are fitted with ball bearings for easy movement in any direction. When the table is full and the casters are on the floor, grasp the handle of the table and pull away from the machine (Illustration 99).

When lowering the delivery table by hand, do not continue to unwind the cable after the table reaches the floor as this will cause it to become reversed on the drum and cause damage. **To eliminate the necessity of stopping the machine while removing a printed load of stock, a device for continuous delivery has been designed. This extra accessory consists of a rack which is inserted in a holding device above the delivery pile to carry the printed sheets until the new delivery board has been put into place (further details see pages 125—126).**

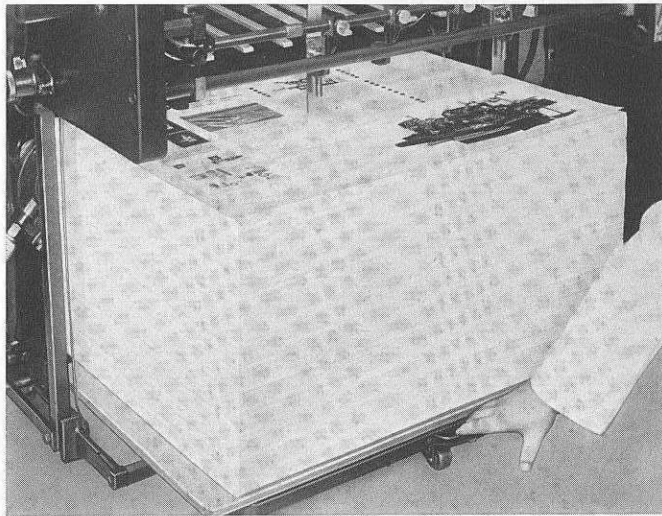

Illus. 99

Powder or liquid spraying

When purchasing a printing machine the printer has to decide whether it shall be equipped with a liquid or powder spraying apparatus. Opinions vary widely on this subject because powder has certain advantages, one of which is that very small quantities prevent set-off and, therefore, smaller powder particles are in the air. Furthermore, powder can be sifted by wind so that it consists of small particles only which have a suitable size for preventing set-off. Powder is also easier to store

and can be removed from the machine without any difficulties.

Nevertheless, there are some disadvantages in comparison with the liquid spray which cannot be overlooked. In contrast to the wet spray the powder sticks to the paper on the printed parts, while it is wiped or stripped off from the printfree spots of the sheet. The result is that the pile gets wavy and feeding the sheets for the second run might cause difficulties. If half of the sheet is printed on only and this powdered several times there will be a considerable difference in height between the two halves.

When using a liquid spraying apparatus the entire sheet is sprayed and the small particles stick to it so that the surface of the sheet remains even. A further difficulty is the fouling of the brush which has to be cleaned more often than with wet spraying. The powder also falls on the rollers and the forme making a more frequent washing of the forme and rollers necessary although the dust trough on the Original Heidelberg Cylinder prevents this to a large extent.

As outlined already the opinions about the pros and cons both spraying methods differ and it is not our intention to plead for one of them. We leave the decision in this matter to the customer and have equipped the Original Heidelberg Cylinder to take both sprays. The machine price includes either a liquid or a powder spraying apparatus. There is, however, the possibility of fitting both spraying attachments to the machine and to switch over from one device to the other by moving a lever.

We recommend that the Original Heidelberg Cylinder be ordered with both attachments so that the printer is in the position to make use of the advantages of both spraying methods.

Liquid spraying apparatus

The spraying apparatus is an integral part of the machine. The pump that supplies the air pressure, is built into the base at the rear of the machine on the control side. The rear plate of the pump is mounted on the base. Here also is the tap that controls the air blast. When the spraying apparatus is to be used, the wing of the tap must be at right angles to the pipe, so that no air can escape. By closing the tap the air is forced round to the spraying attachment (Illustration 100). **It is essential when the spray is not in use, that this tap is opened wide to allow the pressure to escape. This tap also drains off any superfluous oil that may have accumulated in the pump which is lubricated from the central lubrication system.**

Illus. 100

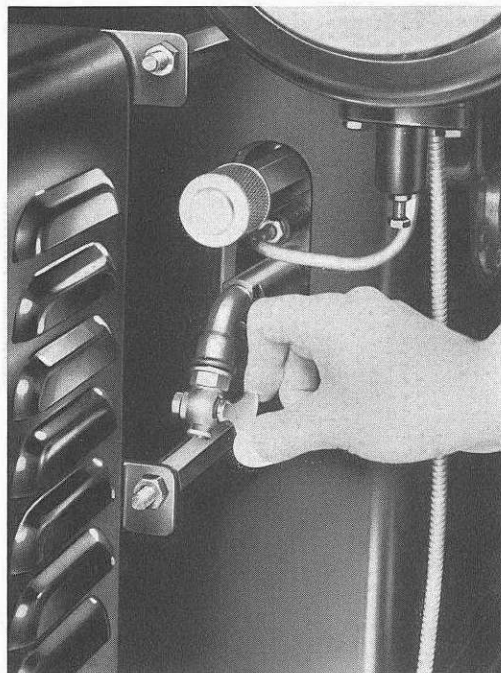

Opening or closing the tap only causes the air blast to be led into the connection to the spraying attachment. When the wet spraying apparatus is to be used the lever located at the delivery side frame on the motor side has to be turned upwards on the 'WET' position. This supplies the spraying apparatus with blast air (Illustration 101).

The spraying apparatus is mounted on a tubular frame and can be swung away from the machine when not in use, and for cleaning purposes. The apparatus can be adjusted for height, after loosening a thumbscrew in the collar just above the workable, by raising or lowering the tube. The lowest position is fixed by a shoulder on the tubular frame. Adjustment for height is necessary because some spraying fluids require a longer time to atomize than others. The maximum height to which it can be raised above the printed sheet is approx. 17" (85 cm). The average setting required is 32" (75 cm).

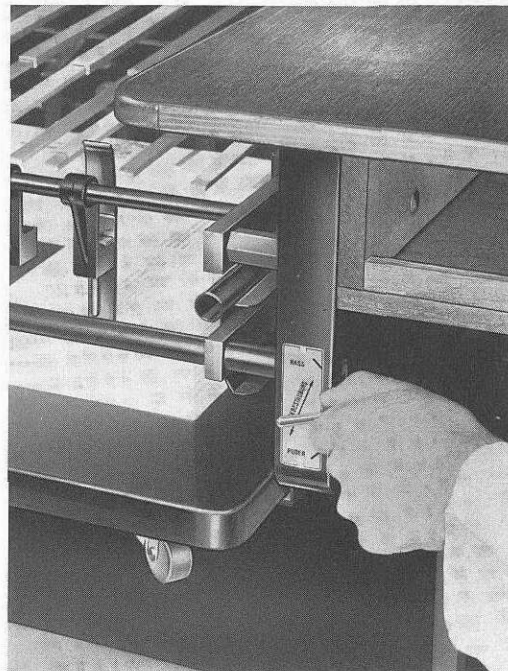

Illus. 101

On the horizontal part of the frame on which the spray gun is mounted, there is a short length of open ended tube in which the glass container is placed when the spray is to be used.

First fill the glass container with spraying fluid. This fluid is gravity fed to the gun. Set cocks were purposely avoided as they get easily clogged and cannot be either opened or closed. When the spraying apparatus is not in use the glass container should be transferred to the lower bracket, and if it is not required for a long period, it should be emptied. There is no need to empty the container for short periods of idleness.

Always regulate the amount of spraying solution atomized to conform to the requirements of the printed sheet. This is done by means of the set screw in the rear of the gun (Illustration 102).

Turning the screw clockwise reduces the amount of spray. Conversely, turning the screw anticlockwise increases the amount of spray. The operator should always economize as much as possible with the amount of spray atomized.

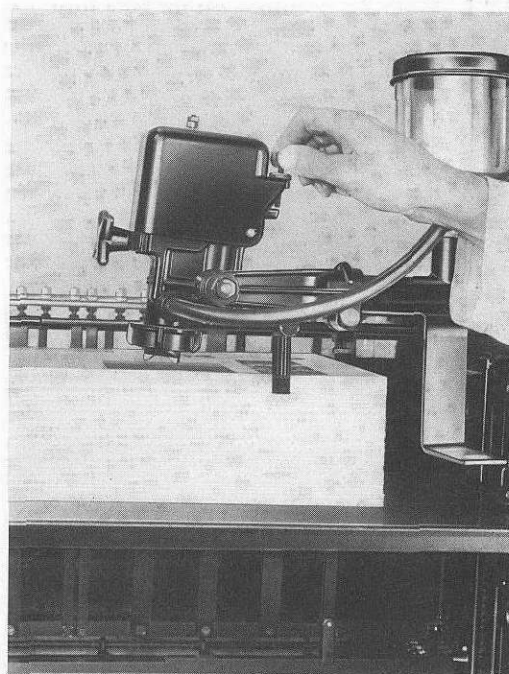

Illus. 102

Directing the spray

The direction of the spray can be adjusted and directed to the part of the printed sheet needing it most. Not every forme is the same, for instance, one half of the sheet may contain several solids whilst the other half is text matter. In such cases the main body of the spray should be directed to the part of the sheet containing the solids. That is the place where most ink has to set. The spray gun is so mounted that it can be moved in any required direction. Two types of spray caps are supplied with the apparatus. One distributes a circular spray and the other an oval shaped one. The cap for the circular spray should be fitted when certain blocks or part of the sheet only are to be sprayed. The cap for the oval shaped spray should be fitted when the entire surface of the sheet has to be sprayed. The direction of the oval

shaped spray can be altered to suit the requirements of the sheet. First loosen the black ribbed cap; the spray cap can then be turned to the required direction and the fixing cap retightened.

To ascertain the extent or direction of the spray, hold a sheet of paper approximately 2" (5 cm) below the nozzle and let it spray the sheet. The atomized solution forms an oval on the sheet indicating the direction and shape of the spray. To obtain the desired direction the spray cap has to be turned by means of the two projections so that these alter their direction. To change the spray cap, remove the black ribbed cap, take out the spray cap, replace with another and tighten fixing cap. Greatest care should be exercised in making adjustments on the spraying apparatus as it is a delicate instrument and if forced or damaged will not function effectively.

Cleaning the spraying apparatus

During the run of a job being sprayed, the fluid can remain in the container overnight and the container may remain in the upper position.

If the spraying apparatus is not required for a long period, we recommend that the spray gun be flushed through with water. The container is emptied of the fluid and refilled with water. Run the machine empty, with the spraying apparatus on, and

continue running until the water has removed all traces of spraying solution. When this is achieved the container should be topped up with water to the level of the spray needle and left until the apparatus is required again.

The spraying apparatus should be thoroughly cleaned from time to time and also when it is not functioning correctly. Before emptying the spraying fluid from the container, it should be placed on the lower bracket so that the supply of fluid to the gun is stopped and the pipe is drained.

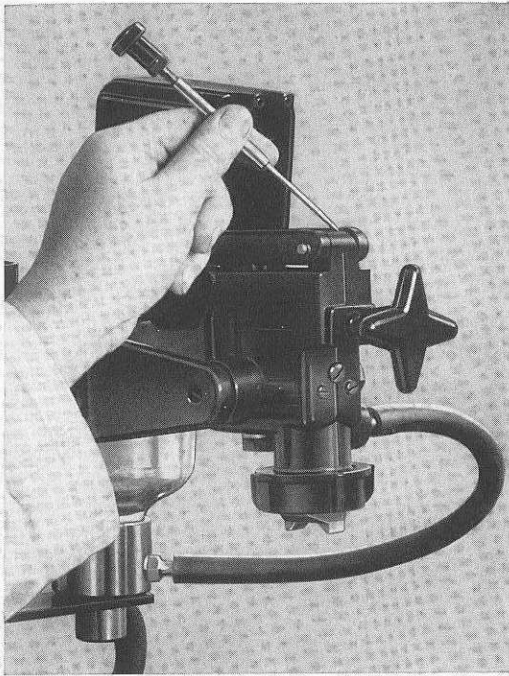

Illus. 103

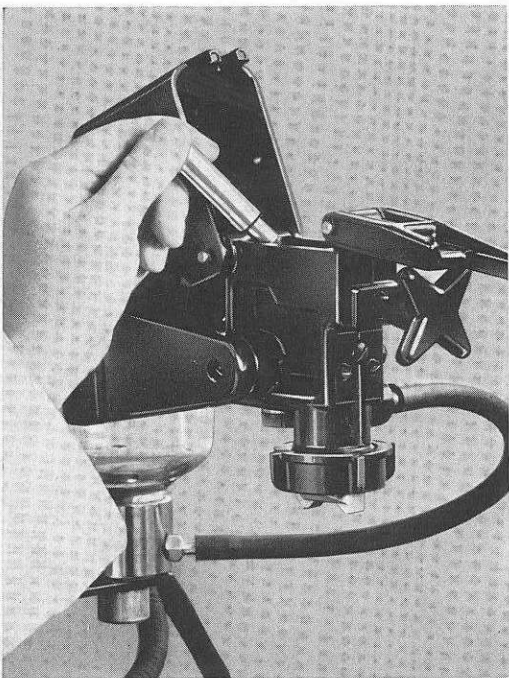

Loosen the screw on the cover of the gun and lay the cover right back. By raising the retaining lever the needle is partially raised and can be gently withdrawn with the fingers (Illustration 103). The retaining lever is tipped back and the plunger can be withdrawn; cleaned, oiled sparingly and replaced (Illustration 104).

The retaining lever can be dropped back into position. The retaining cap and the spray cap are removed for cleaning.

After cleaning and very slightly oiling, the spray needle can be re-inserted through the hole in the retaining lever. Care should be exercised that it is not bent and that hard objects are not used when cleaning it.

The spray needle has an adjustable head. When the needle has been pushed right home and fits tightly in the nozzle, there should be between $\frac{5}{64}$ " to $\frac{5}{32}$ " (2 to 4 mm) play between the head of the needle and its seat in the retaining lever. If there is no such play the head of the spray needle must be adjusted accordingly. First loosen the hexagonal locking nut, make the necessary adjustment and retighten locking nut. This adjustment is very important and should be checked if the nozzle drips.

All parts of the spray gun, especially the needle should be handled with care. Use best quality oil only.

After a job on which the spraying apparatus has been used is completed, the entire machine should be carefully cleaned and all traces of spray deposit removed.

Illus. 104

Powder apparatus

The air blast for the powder spray apparatus is supplied by the same pump as for the wet spraying apparatus. What was mentioned about the supply of air in the chapter "Liquid Spraying Apparatus" applies here as well. The powder container sits in a hole of the work table on the motor side of the machine and can be turned so that the 4 pipes with the 6 jets are over or away from the delivery pile. When the powder spray apparatus is to be used, the lever located on the delivery side frame on the motor side has to be turned downwards an "POWDER" position. This supplies the powder spray apparatus with air (Illustration 105).

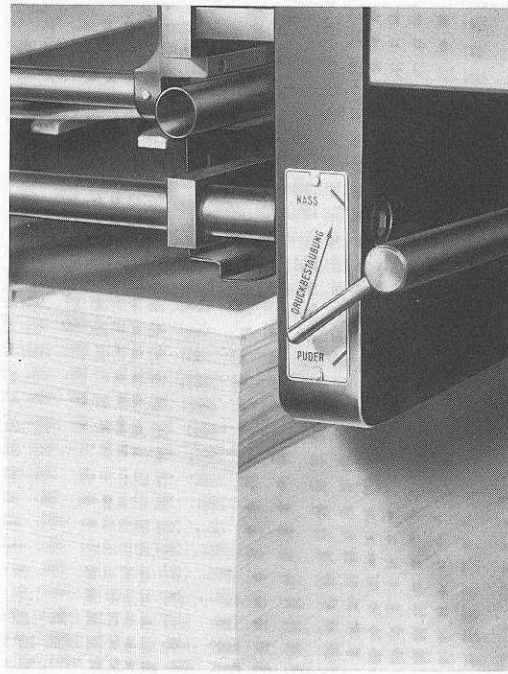

Illus. 105

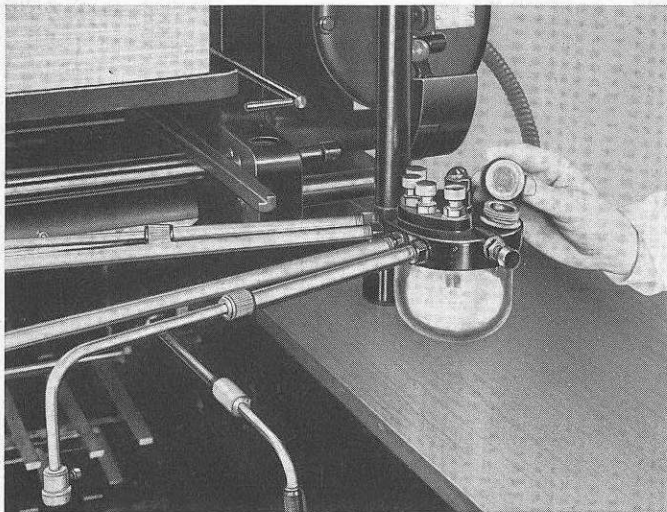

Illustration 106. The cover of the powder container is provided with a big hole for filling the powder in the container. The hole is covered by a screw cap.

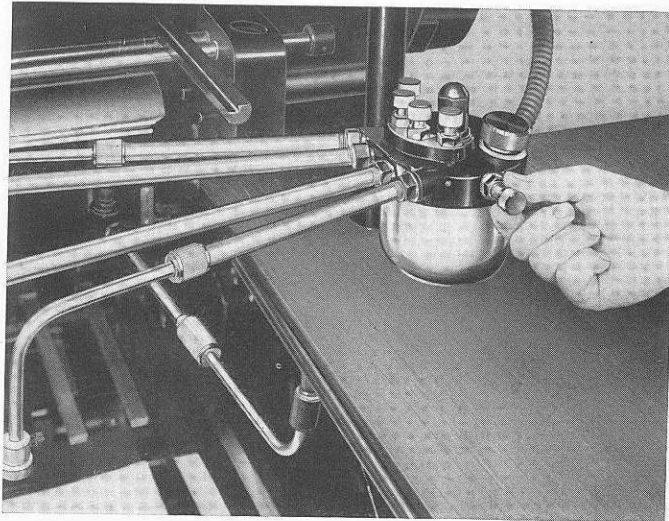

Illustration 107. A screw valve is located on the side of the cover by which the amount of powder to be used for spraying can be increased or reduced equally for all the 4 jets.

The amount of powder should not only be regulated with the screw valves on top of the cover for the powder container but also with the screw valve on the side of the cover, which regulates the air blast inside the glass container. When only a portion of the sheet has to be sprayed the screw valves on top of the cover can be shut off individ-

ually. It may happen that a small amount of powder will still come out of these disengaged jets. The reason for this is that the air blast within the glass container is too strong. If this happens the screw valve on the side of the cover has to be screwed in until no more powder comes out of the disengaged jets.

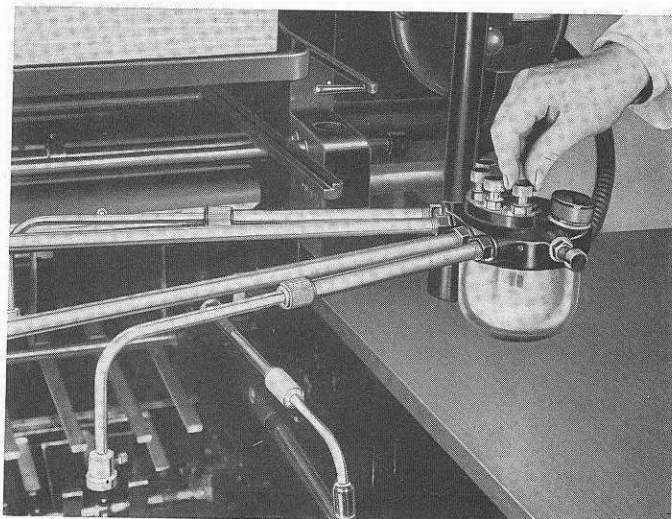
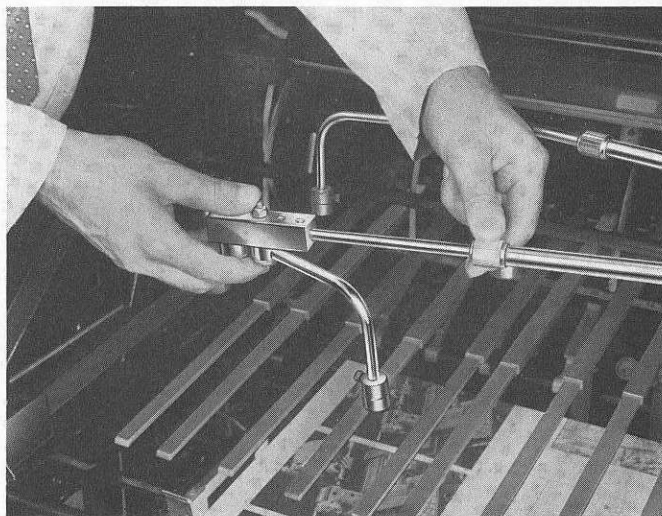

Illustration 108. On top of the cover is a screw valve behind each pipe for regulating the amount of powder for each jet separately. These screw valves also serve for disengaging the single jets completely if only a part of the sheet is to be sprayed.

Illustration 109. The angular pipes with the jets can be pushed in or pulled out so that they become longer or shorter just as required. The pipe with the jet can be turned sideways.



Cleaning the powder apparatus

Illustration 110. From time to time powder deposits have to be removed from the pipes and the jets. The pipes have to be loosened by a spanner and unscrewed.

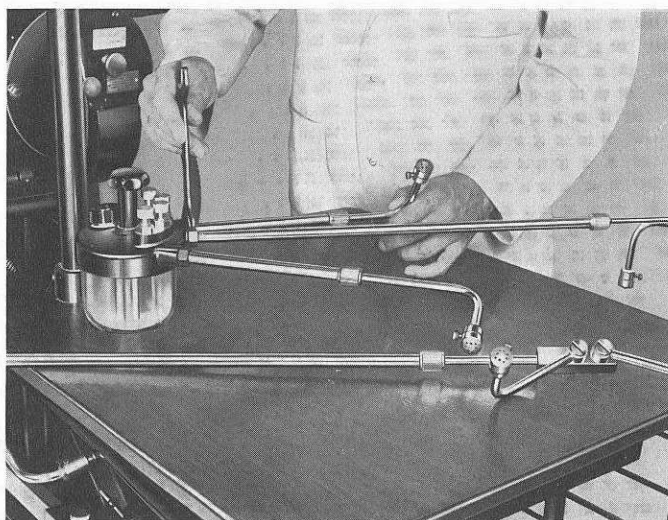

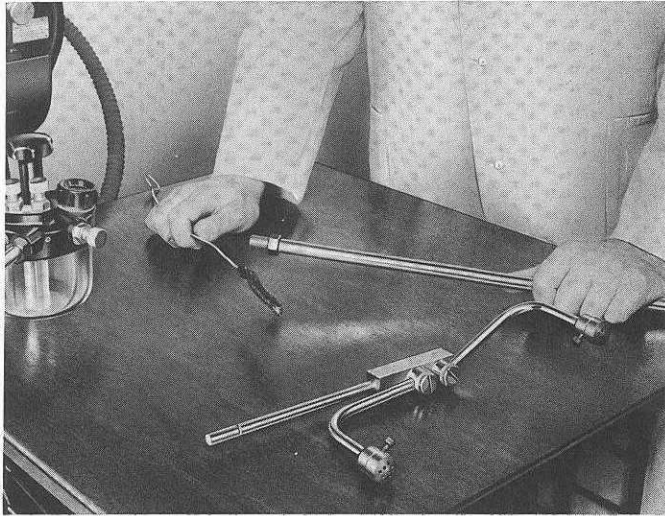

Illustration 111 shows the straight piece of pipe, the angular pipe, the ring for fixing the angular pipe in its position, the jet, and the screw for securing the jet. The two pipes have to be cleaned with the brush.

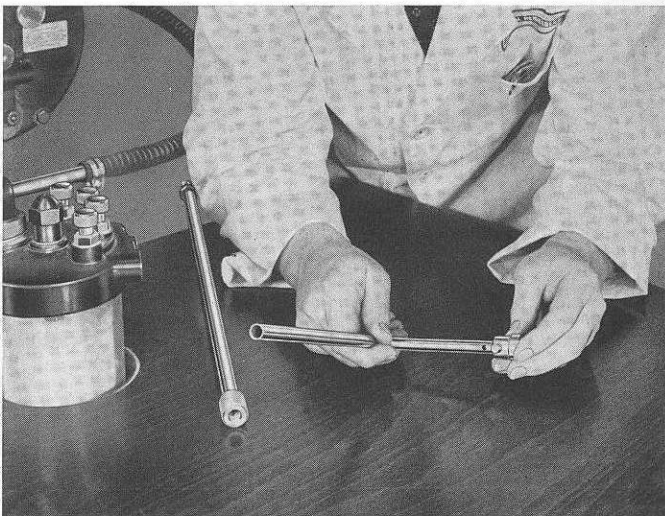

Illustration 112. When pushing the jet on to the angular pipe, the safety screw must be screwed into the hole provided.

Other points to be observed when using the spraying apparatus

It must be borne in mind that spraying does not dry the ink any quicker but merely prevents set-off. Care should therefore be taken when checking the freshly printed sheets. They must not be rubbed against each other and a pile of sheets must not be held tightly in the hands, otherwise set-off will occur despite spraying. The best way to check for set-off is to run through the first 200 sheets after setting the spray gun; this allows for a certain amount of weight being placed on the bottom sheet of the pile. Should it be found that the bottom sheets are showing signs of set-off the amount of spray or powder should be slightly increased by making the necessary adjustment.

To print heavy formes without interleaving, special care should be taken with the make-ready. Impression should not be too heavy as set-off is most likely to occur where the impression is heaviest. Watch the back of the sheet during the run, and use as little ink is possible. With heavy formes that tend to set off, do not attempt to fill the delivery table, as far too much weight will be put on the bottom of the pile. Divide the pile, according to the danger of set off, into small piles, say from 250 to 500 sheets. Normally a pile of 500 sheets is a safe margin. To make this division conveniently,

have some wooden boards cut that fit on to the delivery table with separate side pieces approximately 4" (12 cm) high. These boards and side pieces can also be ordered directly through us or our representatives.

When the boards are made the front corners should be cut out so that the cut out forms a square with side of 2" (5 cms). If no cut out is made the board hits moving parts of the machine and damage may be caused.

After running off 500 sheets, place one of the side pieces on either side of the printed pile and lay one of the boards across them. Run off a further 500, insert side pieces and a board and repeat the process until the table reaches the floor. It can then be wheeled away (Illustration 113).

For insertion of the delivery boards, the use of the device for continuous delivery is recommended (see pages 125 and 126).

The operator can either free the table at once by restacking the pile as it is, on the floor, or he can wait for an hour before doing so, during which time the danger of set off will have been greatly reduced.

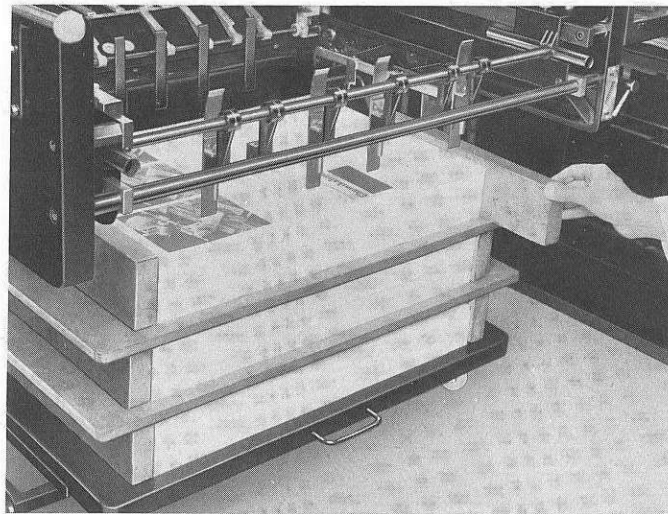

Illus. 113

The impression counter

The machine is equipped with an impression counter situated close to the control lever so that the numbers of sheets printed can be seen at a glance. Before commencing a run, set the counter at nil. Only the printed sheets are counted. The counter only registers when the control lever is at "IMPRESSION" (Illustration 114).

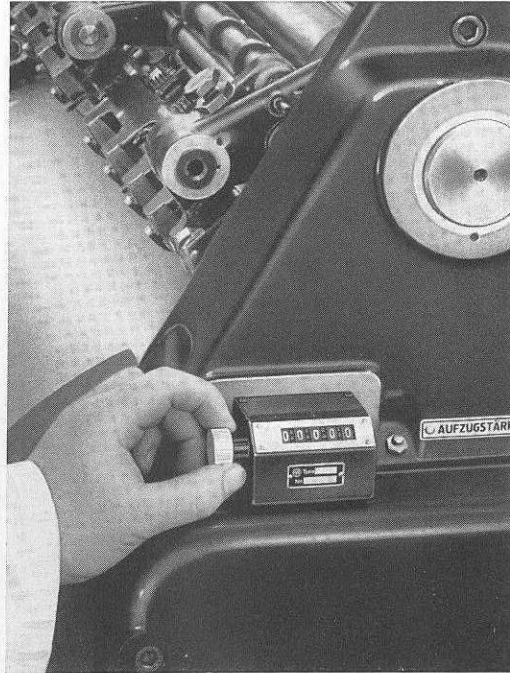

Illus. 114

Tool rack

All tools required for operating the Original Heidelberg Cylinder can be conveniently kept in the tool rack mounted on the rack guard on the driving side of the machine. Tools and accessories should always be put in their correct slots on the rack, they are handy and more easily found (Illus. 115).

Forme and delivery lighting

The type bed and delivery table are illuminated by fluorescent day-light tubes housed in reflectors which extend over the width of the machine. This type of lighting is of great assistance to the operator, especially on the delivery pile, as colour values appear almost normal. Each tube is carefully tested before it leaves the works to ensure that it is in good order. In your own interests, please handle and treat these tubes with every care.

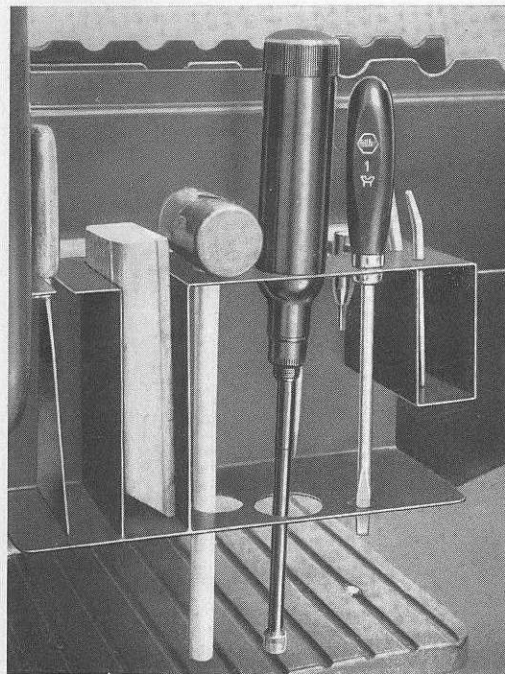

Illus. 115

EXTRA EQUIPMENT

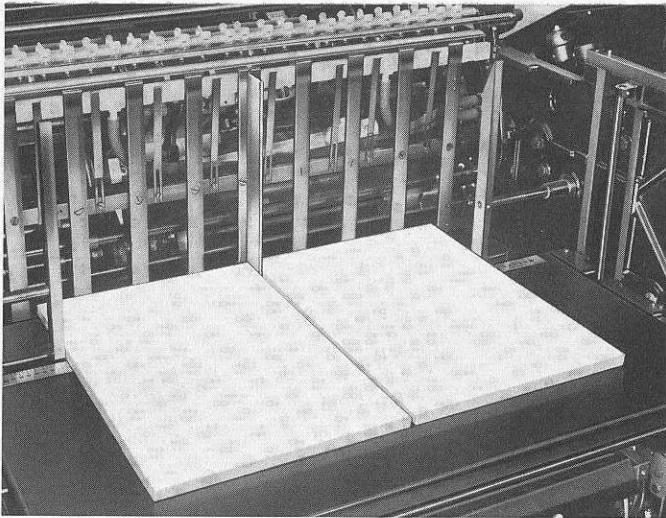

Illus. 116

Device for printing two up

An extra equipment for printing two up can be delivered for the machine. This equipment enables two sheets to be printed side by side at the same time, thus doubling output on smaller sizes. Different jobs can be printed at the same time providing

the papers are of the same thickness. There is no alteration to standard equipment (see Illustration 116). Only a few additional accessories are required and these are fitted in a few minutes to feed and delivery.

A centre divider will be delivered to be fitted between the bars of the front standart. The divider is inserted between the two centre front standard bars and secured with a screw located in the right hand bar (Illustration 117).

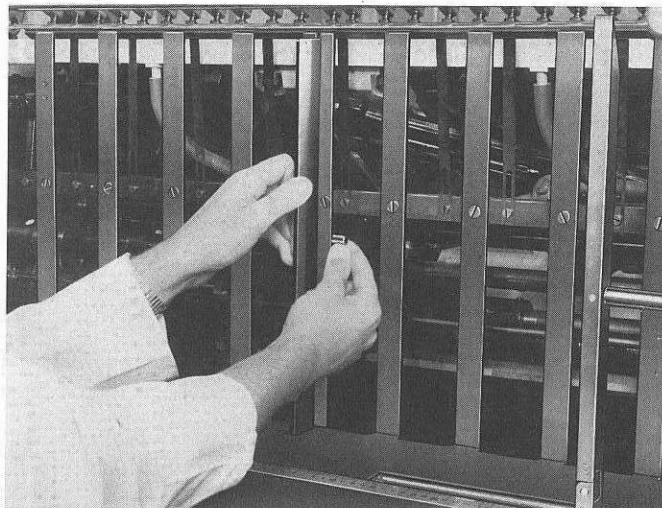

Illus. 117

The delivery must be arranged accordingly.

For the delivery a dividing plate is affixed in the centre to the bar where the holders for the rear standards are mounted (Illus. 118).

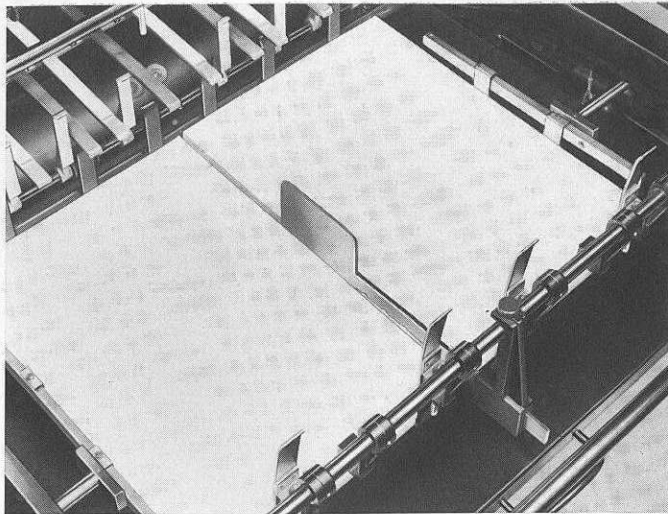

Illus. 118

When printing two-up a lay has to be fixed in the centre of the feed table. For this purpose two brackets to which two extra registering lays can be screwed are fixed to the centre of the bar carrying the side lays.

Of course, it is not intended that both additional lays should be used together. One lay for registering to the left, or one for registering to the right, is to be used as required. On illustration 119 a lay can be seen in the centre which pushes the sheet in the same direction as the standard side lay i.e. from the operator's side to the flywheel side. When using the side lay on the flywheel side, the other lay is inserted so that both lays push the sheets to the operator's side.

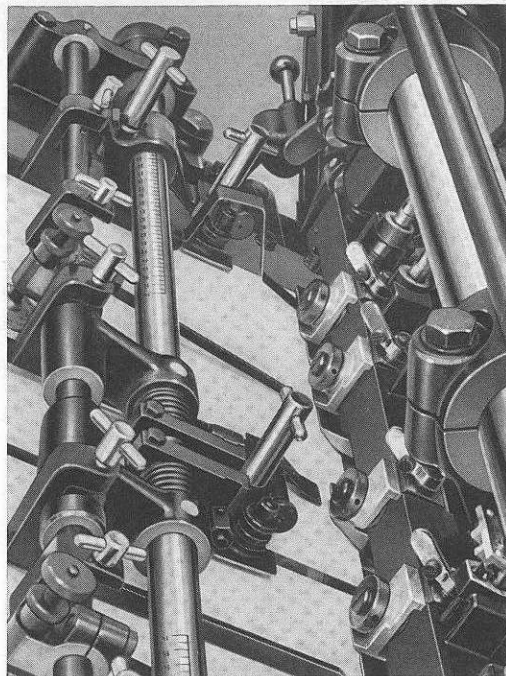

Illus. 119

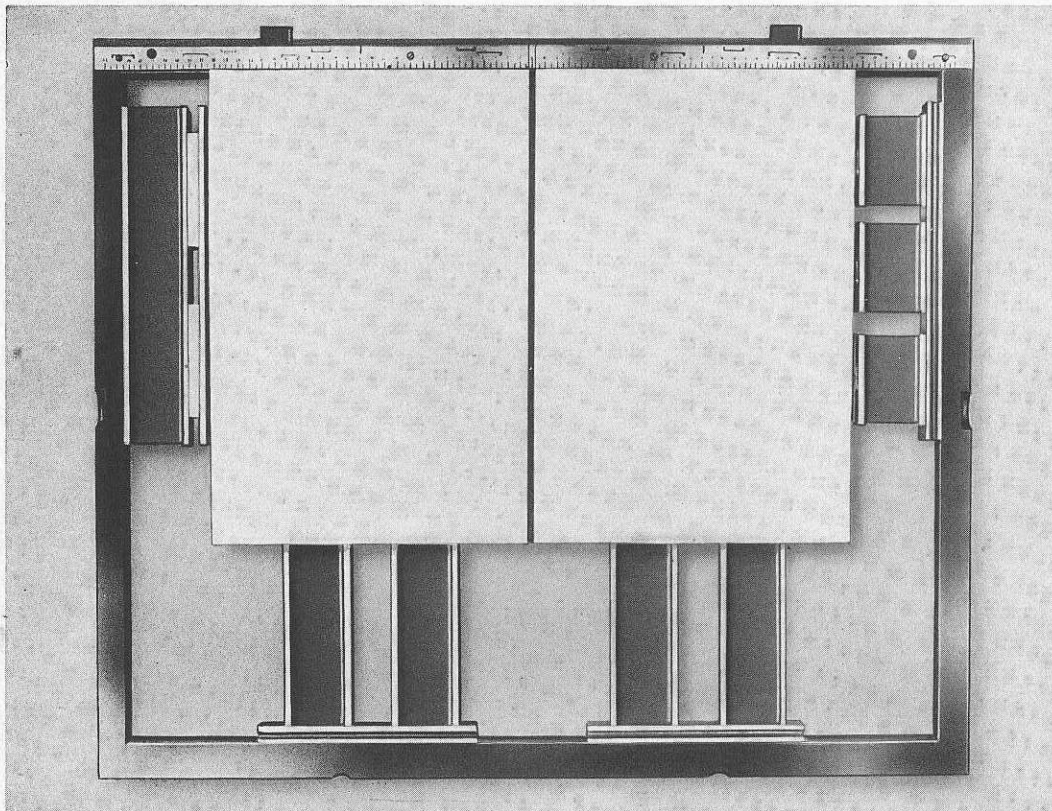

Illus. 120

Locking forme when printing two-up

The forme in the chase must be locked to the centre whether or not the job is 'work and turn'. The inside edges of the sheets must align with the two

lines $\frac{3}{32}$ " right and left of the "0" mark in the centre of the chase (Illus. 120).

Device for printing between bearers

In order that the maximum width of 30" (76 cm) and 32¹/₄" (82 cm) can be printed, a special device for locking matter between the bearers, can be supplied. The chase is substituted by two bars that fit at the head and tail of the type bed. The tail bar fits into one of four conveniently spaced slots in the bearers and is locked into position with a

forme key. Sideways, the matter is locked with ordinary quoins, against the bearers. If the tail bar is placed at the utmost end of the type bed, the chase bolts are put into their locking position and tightened as is the case with the chase. When locking up, proceed as follows:

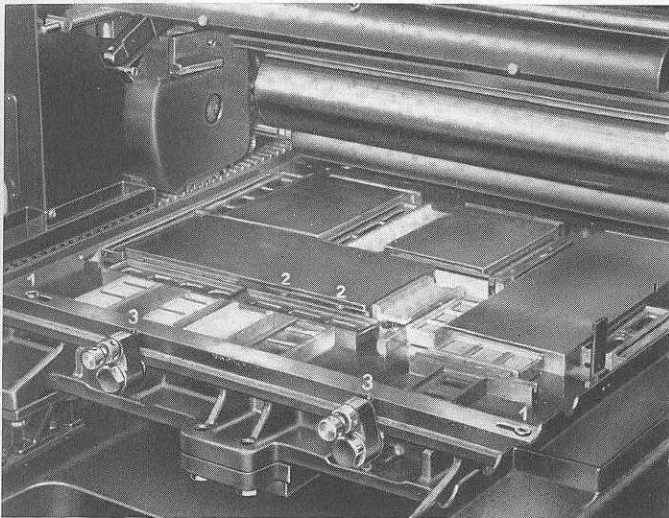

1. Lock the tail bar in the grooves of the bearers.
2. Tighten the quoins in the forme.
3. Put the chase locks into position, when the tail bar is located at the end of the type bed Illustration 121 (Also see page 70).

Illus. 121

Device for hot embossing

The enormous impressional strength and absolute rigidity of the Original Heidelberg Cylinder suitable for economic production with heavy embossing formes. With due care to makeready, the Original Heidelberg Cylinder can produce embossed impressions at an average speed of 3,000 i.p.h. The machine can be used for cold embossing and hot embossing. A special device has been designed for hot embossing on the Original Heidelberg Cylinder to enable even the most difficult embossing jobs to be handled successfully. The embossing heater is an apparatus with infra-red bars which heats formes from 70° to 90° centigrade (Illus. 122).

The advantages of hot embossing are:

1. The paper, especially brittle stock or carton, does not break so easily at the outline of the embossing.
2. The embossed outlines are more definite in fine details and the design remains permanent even

when the sheets are stored in large piles over a lengthy period of time.

3. With bronzed prints the lustre of the bronze is enhanced, the effect being most successful on dull chromo paper. The bronze powder must not be ground too finely.
4. Bronze prints do not rub as easily as with cold embossing.

The illustration shows the Heidelberg special heating apparatus being positioned over the embossing forme.

Printers interested in the production of embossing on the Original Heidelberg Cylinder should apply to our agents for the special instruction folder which contains detailed information. Cold embossing can also be done on this machine and no additional equipment is required, but the instruction folder will be found necessary as it explains the adjustment and makeready of the female die and the method of making the male (relief) die on the cylinder.

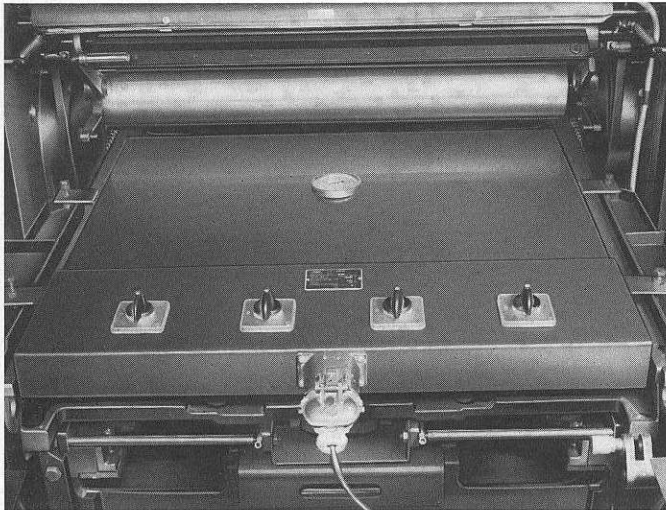

Illus. 122

**Numbering with centrally
controlled numbering boxes on the
Original Heidelberg Cylinder**

For jobs that require a large number of numbering boxes which must work absolutely reliably, as is frequently the case when printing security papers, we recommend the use of our centrally controlled numbering device.

For this method, the Heidelberg Cylinder chase is fitted with moving rods which centrally operate all the numbering boxes in the forme, obviating the need to purchase expensive numbering chases of special design. With the Heidelberg chase, the

numbering boxes can be locked up with ordinary quoins, and type matter and numbering boxes can be worked together in one forme. To operate the moving rods, stops are fitted to the machine which automatically cut out when the machine is running off impression (Illustration 123).

It is possible to operate two moving rods simultaneously with the extra accessory delivered by us so that the numbering boxes can be built in lengthwise and across to the impression cylinder. This also allows the use of numbering boxes of different sizes and with different liftings. Printers interested in numbering on their Heidelberg Cylinders should communicate with their Heidelberg agent for full particulars.

Illus. 123

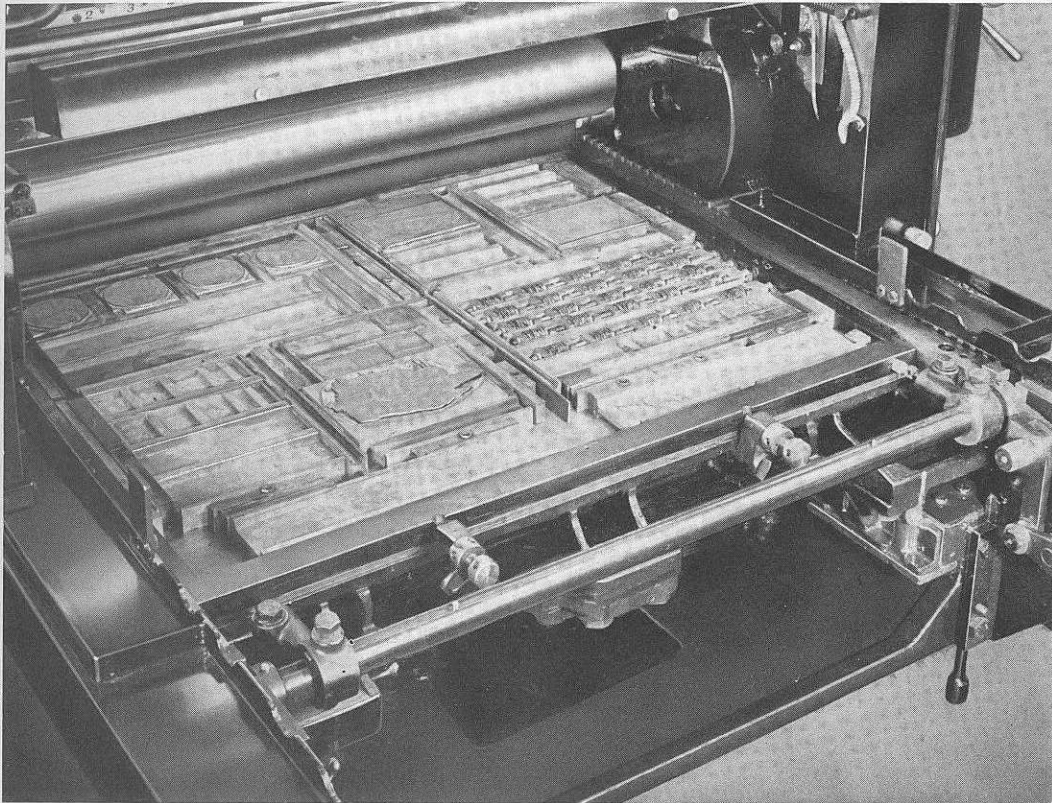

Numbering with plunger operated numbering boxes

When working with plunger operated numbering boxes be sure that you use only those numbering boxes on which the plunger height does not exceed type height by more than $\frac{3}{64}$ " (1.2 mm). This is necessary to prevent the plungers from contacting the cylinder packing. The lower the plunger height,

the better the results will be. Furthermore, low plunger boxes are far less damaging to the forme rollers.

Check with your Heidelberg agent for full details on numbering boxes.

Device for adjusting formes

Modern printshops are increasingly demanding some system of pre-makeready. This cuts down the idle time of the press — which costs a lot of money — to a minimum and increases the earning capacity of the printshop to a remarkable extent.

As an extra accessory a device for pre-registering formes is supplied with the Original Heidelberg Cylinder which cuts down make-ready time on the

machine still further. On multi-colour jobs, straight or slanted imprinting, the plates or type can now be completely positioned in the composing room with the greatest accuracy by using this speedy form register gauge. If desired, we can also supply an imposing surface which is a replica of the type bed of the machine. It is provided with two bed bearers, dogs at the grip edge, and chase locks. With this imposing surface it is possible to completely lock up jobs in register outside of the machine room.

Illustration 124: Imposing surface with side guides which correspond to the bearers on the type bed of the machine, and dogs at the grip edge for securing the chase in position. At the other end, chase locks are positioned as on the type bed so that the chase — which is just being put on in

the picture — can be locked under the same conditions as in the machine. Expansion of the chase when locking the forme which possibly might affect the hair-line register is excluded by this special imposing surface.

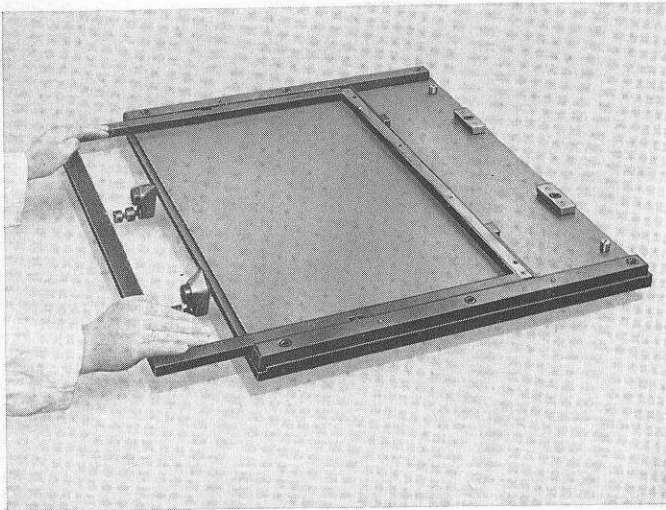

Illus. 124

Illustration 125: Two pin holes are drilled in the head bar of the chase in which the two pins at the hinged frame of the foil can be inserted.

Other when the foil is over the forme is inserted in such a way that the two brass ledges of the hinge lie on top of each other when the foil is over the forme. If the foil is not inserted correctly, type or blocks that are locked directly against the head bar of the chase may become damaged.

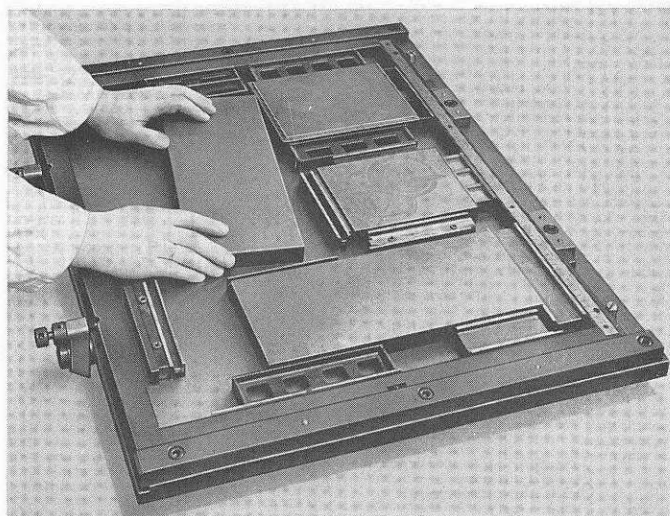
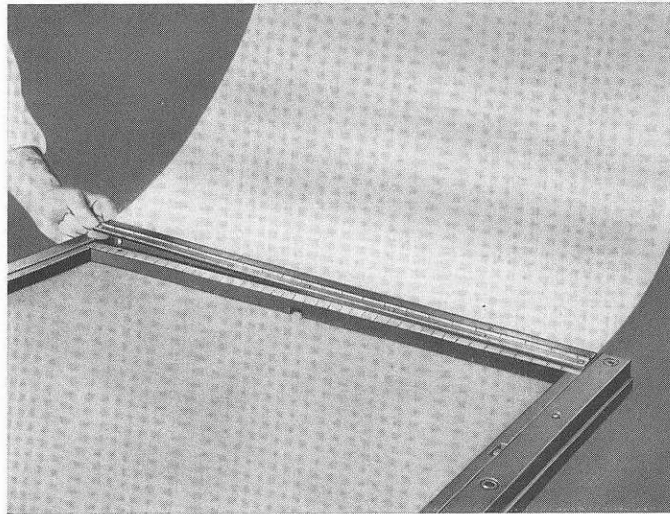

Illustration 126: Positioning the forme in the chase on the special imposing surface.

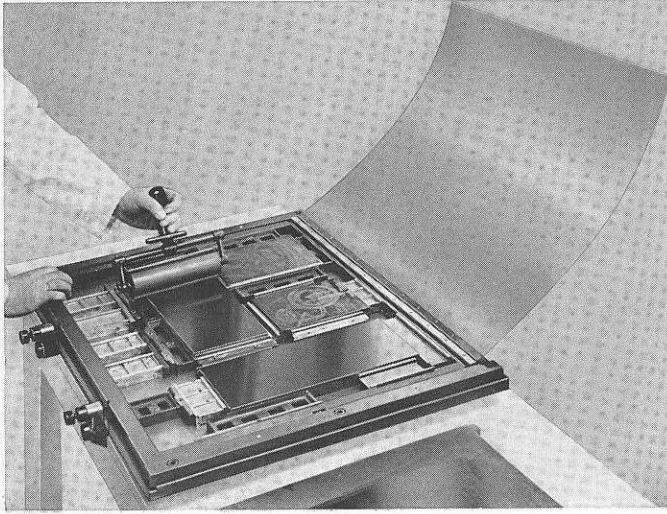

Illustration 127: The forme has been locked and positioned as usual for the first colour in the chase on the special imposing surface. The forme is now well inked with black ink.



Illustration 128: After the forme has been inked the transparent sheet is folded down and an image is obtained by rubbing heavily over the foil.

Adjusting formes to be locked between the bearers

The special imposing surface has been designed to enable the pre-make-ready department to adjust precisely by means of the transparent foil, multi colour work which has to be printed between the bearers. This it possible to take full advantage of the maximum printing width of 30" (76 cm) and 32¹/₄" (82 cm).



Illus. 131: Inserting the head locking bar which is provided with a scale and pin holes for the transparent sheet.

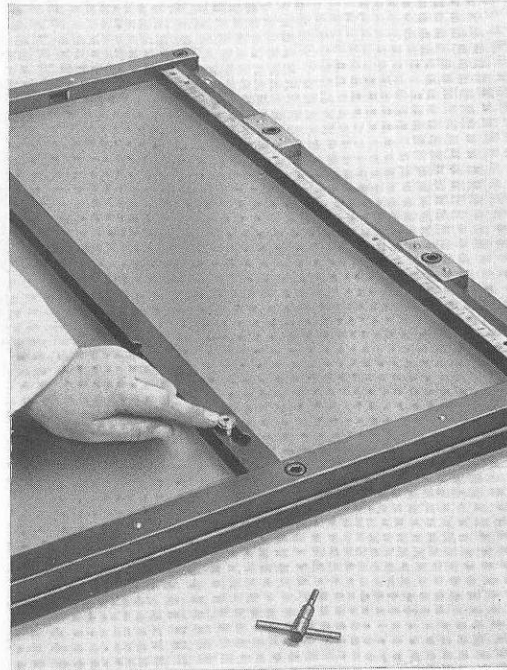

Illus. 132: The rear locking bar is inserted in one of the holes in the bearers corresponding to the length of the forme.

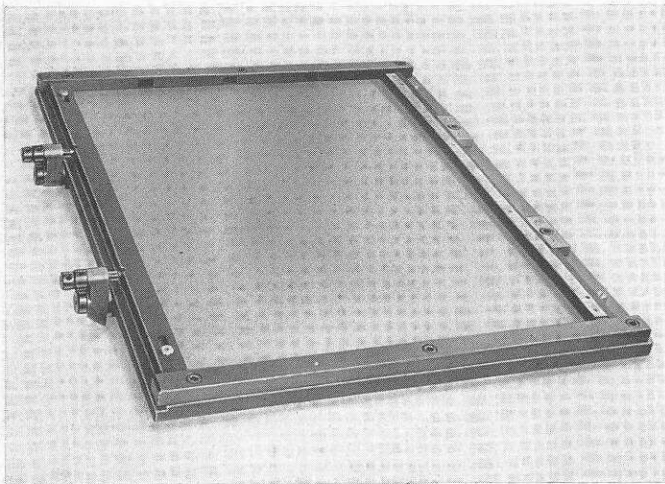

Illus. 133: If the forme covers the entire printing area, the rear locking bar is inserted in the recessed holes of the bearers nearest to the chase locks which are also tightened. The correct locking of a forme between the bearers has already been described on page 113.

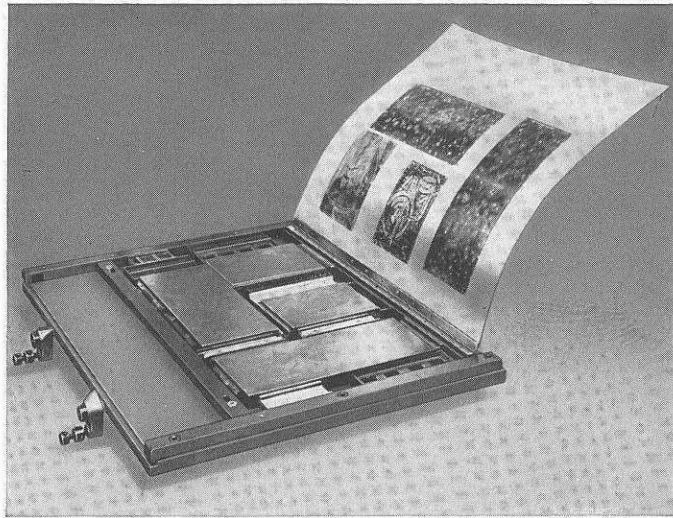

Illus. 134: An image is obtained on the transparent sheet as already mentioned on page 118.

Illus. 135: After loosening the rear locking bar the forme locked between the bearers is slid on to the imposing board and thus can be taken to the machine.



Preloading device for feeder

In order to reduce the idle time of the Original Heidelberg Cylinder as far as possible and to increase still further the average daily output a preloading device is supplied. By using this device a

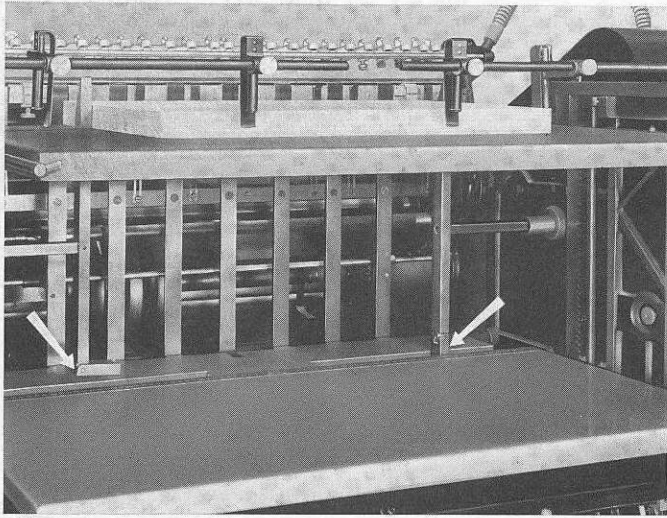

Illus. 136

new pile of paper can be inserted **during the run** of the machine. When the first feed pile has run out to the last sheet the empty feed table can be taken out and the loaded reserve pile can be wound up underneath the sucker bar. The idle time of the machine is cut down to about 1 minute when reloading.

Insertion of preloading device is very simple. The lower ends of both side standards are turned up to the inside, and the preloading feed table placed in position (Illustration 136).

The lower ends of the side standards are turned down and the table is ready for loading.

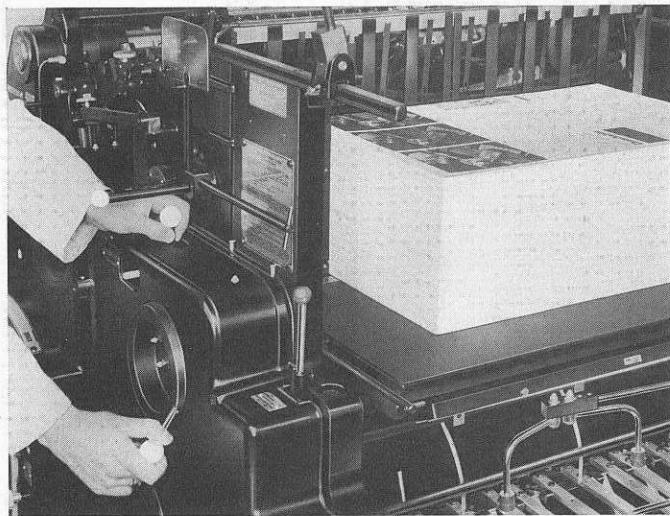

Illustration 137 shows preloading while the machine is in operation.

Illus. 138: When the last sheet on the upper feed table has been fed, the machine stops. After lifting the rear sheet steadiers, the feed pile side standards on each side are released and moved to their extreme outside position. After removing the table, the side standards are moved back against the preloaded feed pile.



Illustration 139: The transporting bars with the table locking device are lowered by means of the handwheel till they descend beneath the spare feed table.



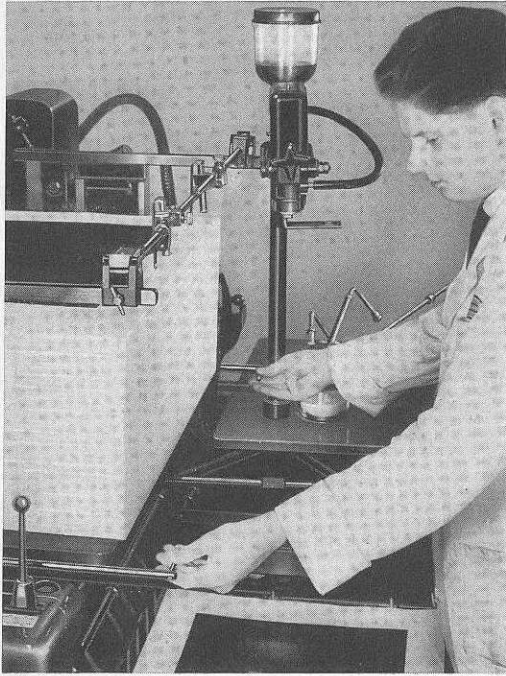

Illustration 140: The table is relocked by turning back the handles of the locking bars.

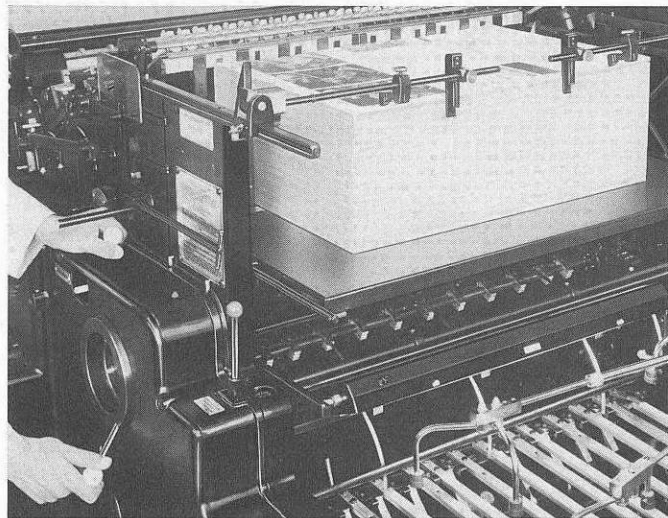

Illustration 141: The spare pile is lifted till the top sheet is about $\frac{3}{8}$ " (1 cm) underneath the sucker bar. The rear paper stops are swung back and the machine is started.

Device for continuous delivery

To avoid stopping the machine when wheeling away the full paper pile or when positioning intermediate boards for the delivery of small piles, a push-in rack is available for the machine. This

carrier rack can be inserted underneath the rods of the delivery carriage, and it will hold the printed sheets until the new delivery board has been put into place.

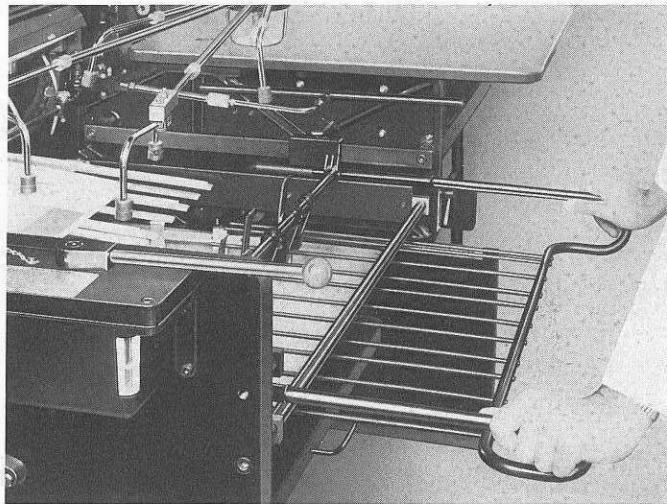

Illustration 142: Inserting the carrier rack in the holding device on the left and right side of the delivery side frame.

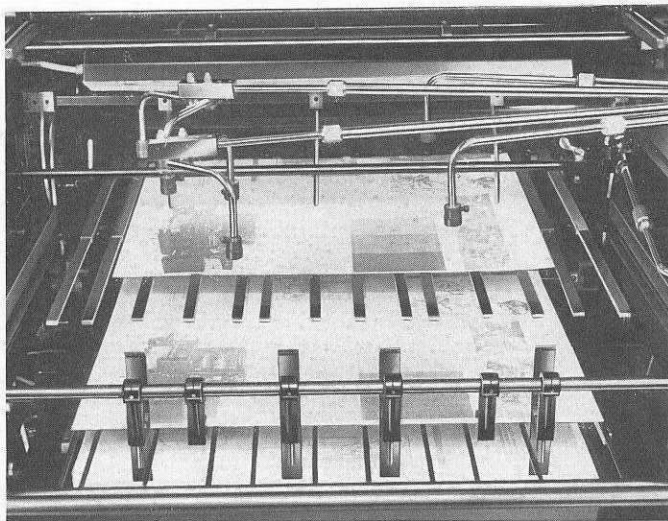
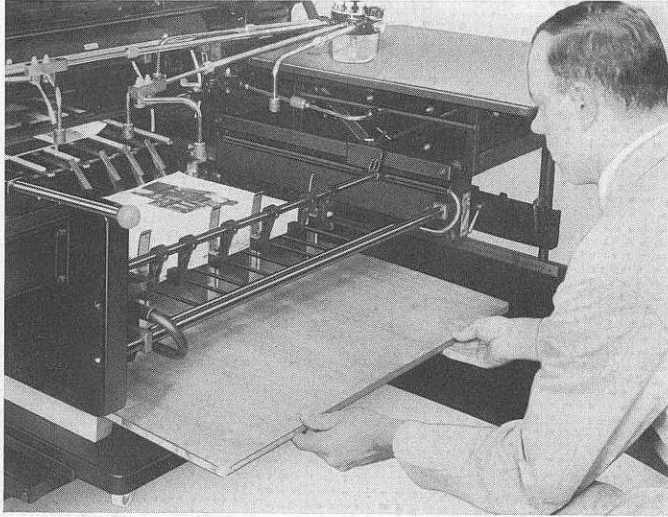

Illustration 143: The rack is inserted and the printed sheet coming out of the machine no longer falls on to the delivery pile but on to the rack.

Illustration 144: While the machine delivers the sheets on the carrier rack, a new intermediate board can be inserted on the delivery pile below it. As soon as the board has been inserted, the whole pile is lifted into the correct position and the

carrier rack is withdrawn. The sheets delivered on the rack will then fall down on the pile. In the same way the following sheets which are coming from the machine without interruption are also delivered on to the pile.



Illus. 144

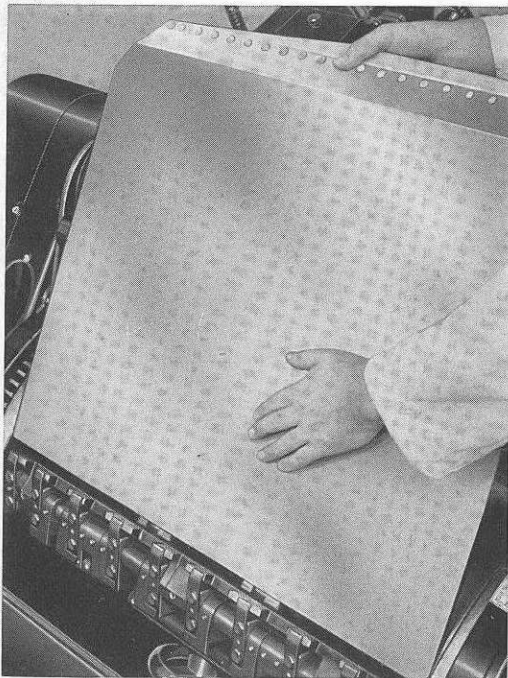

Illus. 145

Die-cutting, scoring, creasing and slitting on the Original Heidelberg Cylinder

The Original Heidelberg Cylinder is especially suitable for die-cutting and creasing by virtue of its strength and the large diameter of its printing cylinder. Furthermore, its high production speed gives it a great advantage over conventional cutting and creasing platens.

Different types of cardboard vary considerably in their flexibility and this, rather than thickness, is the deciding factor in assessing the suitability of a board for running on the Original Heidelberg Cylinder. It is advisable in all cases to have boards cut with the grain running parallel to the cylinder

grippers, as the greater amount of flex thus obtained will avoid cracking at the transference to delivery grippers. In no circumstances should a board thicker than .027" (.07 mm), or of a weight greater than 600 gm/m² be used and the stiffer the cardboard the thinner it must be to retain the required flexibility.

The forme is made of steel cutting rules which are anchored in plywood and made to order by firms specializing in the manufacture of cutting formes.

As an extra accessory, we supply a stainless steel die-cutting plate with a thickness of .0315" (0.8 mm). This jacket is curved to fit the cylinder and has a right-angled bend which fits into the packing clamp. When running die-cutting jobs we recommend the use of packing screws instead of the threaded make-ready pins supplied with the press. The angled edge of the plate also has holes which correspond with the screws in the clamping edge of the cylinder. A strong canvas strip is rivetted to the other end of the plate and can be wound tight around the rear draw bar (Illustration 145).

For volume die-cutting or long runs we also supply a hardened steel plate. The rules will not cut into this long lasting hard plate. It preserves the cutting edge of the rule and ensures clean cutting throughout the longest runs.

When large quantities of cutting have to be done, we recommend the use of a hard steel plate $\frac{3}{64}$ " (1 mm) thick **under** the forme. This plate prevents a marking of the type bed by the cutting rules and serves also for fixing the required make-ready **under** the cutting forme.

When no make-ready plate is used under the cutting forme the rules must always be ordered type high. We draw attention to this because the cutting rules for cutting platens and other cutting and creasing machines are generally supplied a little higher than type high. Such cutting rules, however, are not suitable for use on cylinder printing presses as the pressure of the cylinder on the forme would no longer be correct and the cutting rules would cut into the type bed.

When using a make-ready plate under the cutting forme the rules must always be ordered $\frac{3}{64}$ "

(1 mm) below type height. Also, jobs which have to be slit can be very economically carried out on the Original Heidelberg Cylinder. The slitting can be done in the same way as die-cutting except that the cylinder packing has to be reduced as the sheets are not entirely cut but only slightly slit. Slitting can only be carried out by the use of cutting or slitting rule formes which have to be positioned on the type bed and not by means of cutting wheels.

The Original Heidelberg Cylinder can also be used for scoring and creasing work. For scoring and creasing, either a forme composed of creasing rules (1 or 2-point face rules) or our special creasing device should be used. If cutting and creasing is done simultaneously, as is frequently the case in the manufacture of folding boxes, the creasing rules are incorporated in the cutting forme.

Any further information concerning cutting, creasing, scoring etc. on the Original Heidelberg Cylinder may be obtained on application to us or our agents.

Because of their rigid construction, Original Heidelberg Cylinder produce cutting jobs very economically. High production speeds give the Heidelbergs a distinct advantage over heavy and slow cutting machines. Because of its outstanding advantages as a cutting and creasing machine the Original Heidelberg Cylinder is also supplied as a pure cutter and creaser in sheet size $22\frac{1}{2} \times 32\frac{1}{4}$ " (57 x 82 cm) (see pages 142 to 145).

Device for carbon printing

The versatility of Original Heidelberg is well known to printers throughout the world. Nevertheless, we are constantly exploring new fields in order to widen the application range of the letterpress process. For the production of carbon a heating device is available for the Original Heidelberg Cylinder.

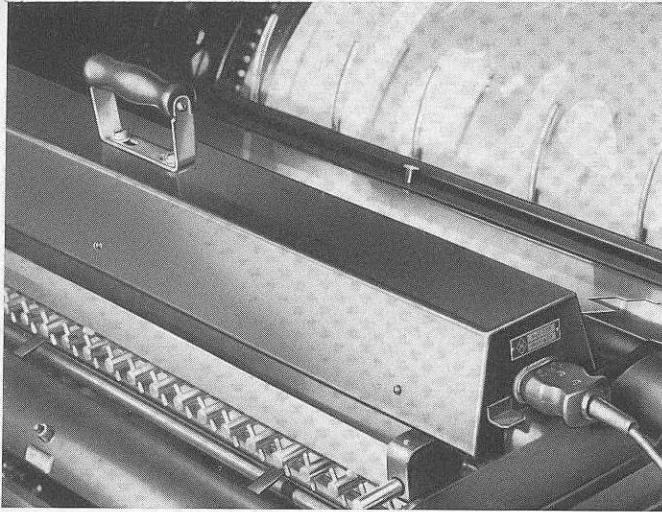

Illus. 146

For ordinary small carbon runs, we recommend the use of our heating unit for the ink duct, especially when the machine room is cold. This ink duct heating device is quite simple. — It only requires to be plugged into the electric supply and placed on the duct. No alterations are required to the machine (Illustration 146).

Various ink makers supply carbon inks which do not require to be heated up for these ordinary type carbon jobs. However, as these inks are, by nature, of a very tacky consistency, we recommend that you use our ink duct heating device, especially on cold days. During the winter season, the ink duct heating device can also be used for warming up the normal printing inks.

Devices for eliminating static electricity

The tendency of stock becoming charged with static electricity increases as the speed of production is increased. This is especially true when running thin papers.

Quite often, a piece of stock can be charged with static electricity during the run through the machine; that is, there is no trace of static when feeding but it is increasingly noticeable at the delivery.

By employing a static eliminator excellent results have been achieved. For the Original Heidelberg Cylinder we recommend a high frequency device which operates with electric current.

The static eliminator is fixed to the square bar under the feed table as illustration 147 shows.

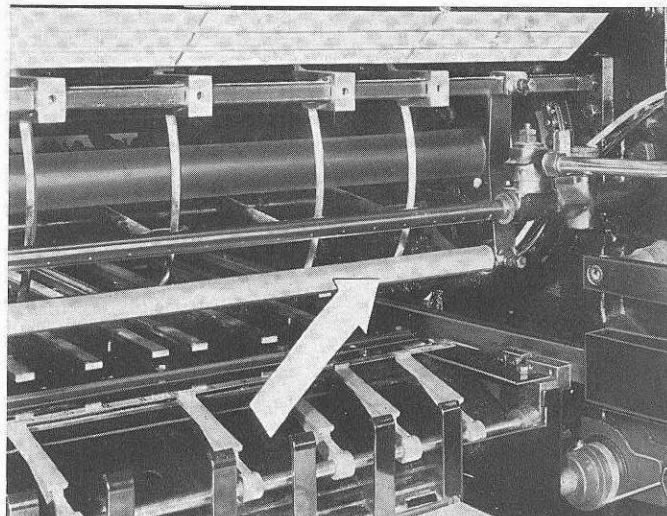

Illus. 147

Tests of the radioactive bar on thin papers have proved to be highly satisfactory. Static electricity of the paper is neutralized by ionization of air. Any balance of electricity is absorbed.

In most cases, maximum printing speed of 4,600 i.p.h. was resumed upon elimination of static electricity, so that correct functioning of the delivery was insured.

If you desire further information on these devices, your Heidelberg agent will be happy to secure it for you.

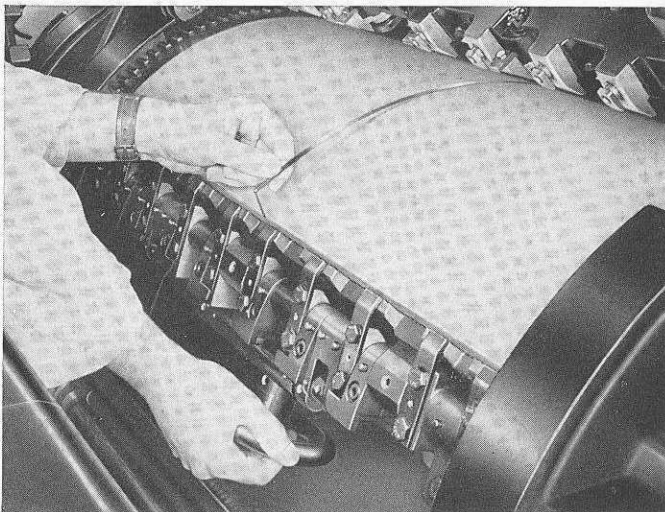

Illus. 149

Perforating and cutting on the Original Heidelberg Cylinder

A special device has been designed for perforating, creasing and cutting on the Original Heidelberg Cylinder. The present sheet guide bar is replaced by a reinforced bar to maintain absolute rigidity during perforation. This bar is affixed with the same hexagon bolts that are used for fastening present sheet guide bar.

In normal perforating work, standard steel bands of $\frac{1}{4}$ " (6 mm) in width are used. ($\frac{1}{8}$ " [3 mm] steel bands can be supplied on special order only.) The steel band is secured at the gripper edge by the packing clamp. (Illustration 148).

The other end of the steel band has a hook and turnbuckle. The hook goes over the rear tympan reel and the turnbuckle draws the steel band tightly to the packing. (Illustration 149). The steel band must be located between cylinder grippers because the perforating wheel must not roll over the cylinder grippers. When positioning for a perforating job, be sure that the perforation is done between the grippers. Remember that the sheet can only be perforated $\frac{5}{16}$ " to $\frac{3}{8}$ " (8–10 mm) from the gripper edge. The bracket of the perforating wheel is mounted on the steel bar which carries the new sheet guards. The perforating bracket is secured by two screws in any desired position. Several perforators can be used simultaneously. The minimum distance between perforating wheels is normally $1\frac{3}{8}$ " (3.5 cm) but on request perforating heads can be supplied to work at a minimum of $\frac{3}{4}$ " between wheels.

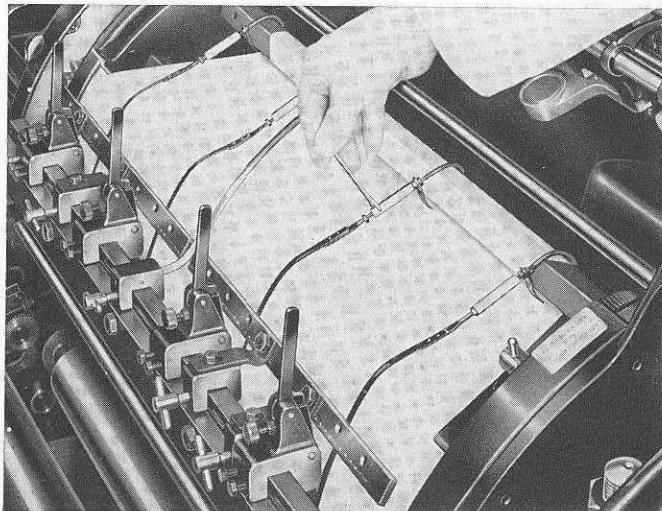

Illus. 148

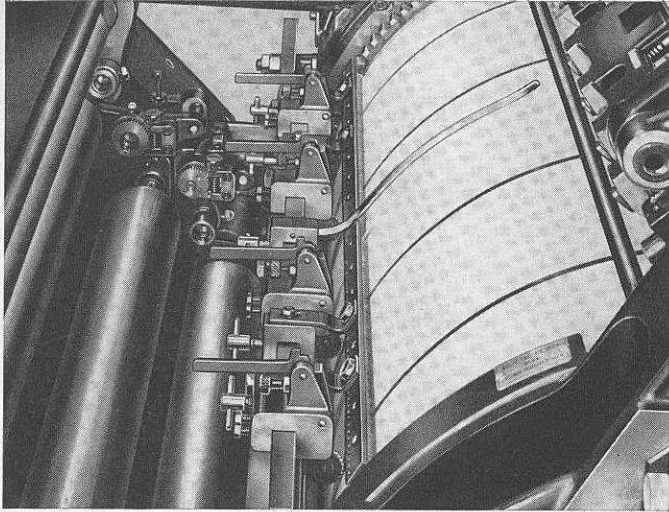

Illus. 150

The perforating wheel is adjusted to the steel band with an adjusting screw on top of the bracket. The long lever must be down when making this adjustment. Perforation on). Adjustment must be made in such a way that the perforating wheel is rolling evenly on the steel band and is not positioned too low.

Illus. 151

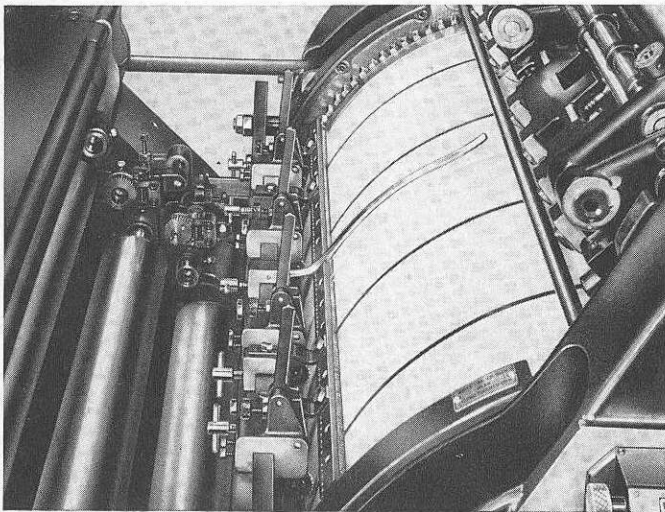

To disengage the perforator the lever is raised to its vertical position so the perforating wheel is drawn back from the steel band. When continuing the perforation the lever is simply lowered. In addition to this extra accessory a brush is supplied which will extend over the whole width of the cylinder. This brush can also be mounted on the bar. It serves to smooth the sheet before perforation begins, and assures even perforation at the edges of the sheet. We recommend the brush for smoothing the sheet even if perforation is done only in the center.

When cutting is desired, the perforating wheels can be replaced with cutting knives. Cutting and perforating can be done simultaneously.

In addition to the perforating device, we also supply a special device for creasing work. This creasing device can be used also for occasional perforating jobs. It consists of a steel bar which is mounted slightly below the normal sheet guide bar of the reinforced steel bar of the perforating device. However, for perforating jobs we would recommend the use of our perforating device, shown on the preceding pages, at its reinforced bar can be left on the machine or swung upward like the normal sheet guide bar, whereas the creasing device has to be taken off the machine after the creasing job has been completed.

For those firms which handle large quantities of perforating and cutting work we have designed our Original Heidelberg Cylinder cutting creaser (see pages 142—145).

Device for printing onion skin

As described on page 88 the automatic cut-out device on the swinging gripper stops the machine if the feed table grippers fail to deliver a sheet.

When printing extremely thin paper a special device is available to permit finer adjustment of the cut-out rods. This will ensure a smoother feed to the front place. Illustration 152 shows the device for printing onion skin mounted to the control rods.

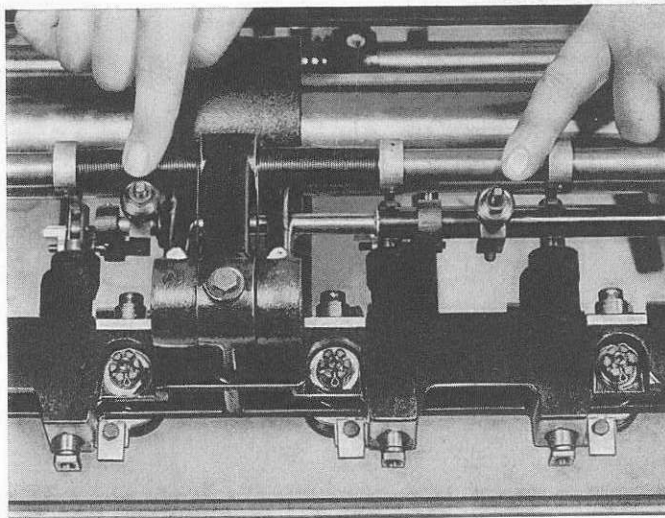

Illus. 152

DIFFICULTIES AND REMEDIES

Many of the troubles which the printer may experience and that have no connection with the machine itself are described in the chapter "Printing in General". These pages contain hints on how to treat forme, ink and rollers to obtain good printing results.

Furthermore, we should like to emphasize that the correct maintenance of the machine is, of course, the most important factor in achieving trouble free operation. Strict attention to the cleaning and oiling procedure increases the machine's duration of life and saves the expense of repairs.

Paper

Obtaining a good reproduction from the forme depends to a great extent on the condition and the quality of the stock. Every printer knows that not all paper surfaces are suitable for printing any particular job, and generally, no one would try to produce a quality job with fine screen blocks on anything but art paper. Paper which is merely calendered, or rough surfaced paper, will result in a loss of sharpness of reproduction. These things are generally known and, therefore, it is unnecessary to discuss them in detail.

We do know from experience, however, that the importance of careful treatment and storage of paper has to be pointed out repeatedly, because it is, in this respect, that many of the smaller and medium-sized printing houses build up trouble for themselves in later stages of production. Admittedly, space is rare and expensive, and that is why many a printer will allow as much space as possible for the production machines and cut down on unproductive storage space. This conception is sound enough from the economical point of view but, obviously, should not be carried to an extent where the condition of the printing stock will cause reduced production by its behaviour on the machines.

The stock which is supplied by the paper mills is usually, in these days, matured and in good condition, and the far-sighted printer will always maintain sufficient paper of standard kinds in stock. The advantages of holding paper in stock, against

ordering as required, become clear when one considers the following points. The room in which the paper is stored should have the same climatic conditions as the press room in which the paper later will be printed, i.e. the humidity and temperature should be the same as in the press room. Stock coming from the paper mills should be immediately unwrapped and stored in small piles on racks. This is the only way to air the stock and to give it an opportunity to adapt itself to the climatic conditions of the paper store room. Before printing is started, it is best, even if the store room and the press room have almost the same climatic conditions, to bring the stock into the press room some time before starting the run, so that it settles to the temperature and humidity of the press room.

Also, it is emphasized once more that the stock should be kept unwrapped and in small piles. If, during a long run the humidity and temperature cannot be kept constant, the piles should be covered with paper to keep out as much air as possible, especially when printing quality jobs with hair-line register.

The best temperature for the press room lies between 20° to 22° Celsius or 70° Fahrenheit at a relative humidity of 55—60%. It is important that a temperature and humidity as close as possible to these specifications is maintained not only during working time but also overnight and during holidays. A drop in temperature in the morning when work is beginning causes trouble with the ink, rollers, and the paper, and these difficulties will last until normal conditions are reached.

Besides the problem of working the stock caused by varying climatic conditions, another trouble may appear which is well-known to every printer, namely that of the stock becoming charged with static electricity.

Static has driven many a printer almost to despair when every method of running the charged stock has been tried without success. The Original Heidelberg Cylinder has an advantage in comparison with other presses in that the feed board is made of an aluminium alloy, so that many of the disconcerting stops that occur on machines equipped with wooden feed boards are avoided. Further, the sheet is permanently guided by grippers when

running through the machine, and, not being transported by rollers or tapes, it cannot stick by static to machine parts on its way. The only moment where the sheet is not so guided is during registering on the feed board, but here the static, as we already mentioned, is neutralized by the alloy of the feed board so that the sheet can be pushed accurately to dead register.

The above details reveal clearly, that as far as possible, everything was taken into consideration when designing the machine to keep the troubles resulting from static-charged paper to the minimum. As static is, however, a most malicious pest which observes no rules, we shall describe some of the means which the printer may try to eliminate the causes of charging or to reduce the consequences to an acceptable extent.

Printers have developed many different methods but, unfortunately, none of these guarantee an absolutely safe remedy and one has little alternative but to try out the various methods, one of which, perhaps, will work in a certain case.

As already explained, the charging of stock with static electricity is associated with the climatic conditions in the press room and especially with dry air. Therefore, it is important to eliminate this cause, and if there is no equipment for air conditioning which automatically regulates the humidity, the printer may have to resort to a method which is, in itself, very primitive but which has worked successfully in some cases. This expedient is to sprinkle water on the floor of the press room so that the air gets a higher percentage of humidity by the evaporating water. The effectiveness of this method is very doubtful as the amount of moisture cannot be controlled, and there are many other disadvantages in having a wet floor.

A better way, which is especially used in countries with a very dry climate, is to fill the container of the wet spraying apparatus with water and to spray a very fine mist near the feed and delivery pile. If this is done, however, the machine has to be carefully cleaned and oiled afterwards to avoid rusting.

To neutralize the charging of the sheet when passing the cylinder brush, printers may rub the top

sheet of the packing with glycerine or paraffin (kerosene). The disadvantage of this method is that the glycerine sinks into the packing and causes it to swell, introducing difficulties of another kind. When this method is practiced, an oiled sheet should be laid under the top sheet to prevent the glycerine from penetrating the whole packing. As the glycerine will have to be renewed several times during the run it is, perhaps, more effective to use an aluminium foil as a top sheet instead of rubbing with glycerine. The aluminium foil, however, must touch the bare metal surface of the cylinder to neutralize the static; in other words, it must be earthed. If there is a tendency towards charging with static, the cylinder brush should be adjusted against the cylinder as lightly as possible.

Causes of bad sheet separation and pick up of two sheets on the feed pile

1. Paper was not fanned out properly before loading the feed table.
2. Sheet edges are burred by cutting with a dull knife on the cutting machine.
3. Stock curls up or down on the front edge so that the air blast for sheet separation is deflected and does not separate the sheets. If the stock is curled up, it should be counter-rolled before building the pile up. If the stock is curled down, the pile must be equalized by underlaying cardboard strips or wood furniture.
4. Rubber tubes or connections are faulty.
5. Insufficient air blast by:
 - a) too high or too low positioning of blower,
 - b) blower holes obstructed by paper dust or dust from the dry or wet sprayer,
 - c) blower is oily because the air pump was over-oiled with a too thin grease or oil,
 - d) the flat spring of the valve in the air pump is damaged or broken,
 - e) air blast between the blower on the feed pile and the blower directly above the delivery pile is not correctly balanced.

6. Too much suction with thin, light, or porous stock. (Use airmail slides. Open as far as necessary all suckers which are not positioned directly over the pile.)
7. Feed table is too high, so that with porous stock two sheets are picked up together.
8. Standards, or the rear sheet stops, are too tight against the pile, causing the sheet to jam.
9. Front tripping springs are not adjusted correctly or tripping springs with the wrong claws are inserted.
10. Lateral tripping springs not correctly adjusted.
11. Sheets stick together by
 - a) sheet edges which became moist,
 - b) badly dried ink,
 - c) wet spray, if the wet sprayer was not accurately adjusted and drops fell on the stock.
4. Wrong, or wrongly adjusted, tripping springs keep sheet down.
5. Rear sheet stops are not positioned near enough so that the sheet is being blown back by the blower.
6. Too much or not enough air blast from the blower.
7. Sucker bar tilt not correctly adjusted.
8. Pile too high or too low.
9. Feed table lift not correctly adjusted.
10. Wavy paper which results in some suckers being positioned on top of a wave, other suckers over the wave trough. In bad cases the pile should be equalized by underlaying thick cardboard strips or wooden furniture. Close suckers over the wave troughs to concentrate the vacuum on the high parts of the stock.

Sheet is not picked up

1. The points for bad sheet separation should also be checked if the sucker bar fails to pick up.
2. Insufficient vacuum in the sucker bar.
 - a) Knurled adjusting screw for regulation of the vacuum on the air pump is too far out,
 - b) close suckers which are positioned to the right and left of the pile,
 - c) when running cardboard use rubber suckers,
 - d) suckers are obstructed by paper dust or dust from the wet sprayer,
 - e) thimble shaped vacuum filter in the tube connection (Illustration 72) on the pump is clogged,
 - f) the nozzle for the vacuum tube is obstructed with grease.
3. Standards on the feed table are too tight against the pile so that the sheet is held back.

Feed table grippers do not catch the sheet or do not catch it correctly

1. Rear sheet stops are not adjusted close enough to the pile, therefore the sheet is blown back by the air blast of the blower and is just caught by the suckers without sufficient margin for the feed board grippers. The machine stops automatically.
2. Sheet size in the pile varies too much, causing the same trouble as described in paragraph 1. To remove the risk of such stops it is sometimes advisable to trim the pile on the rear edge before loading it on the feed table.
3. Paper is wavy:
 - a) Try to use airmail slides so that the edge of the sheet is flattened. If the airmail slides do not leave enough suction, enlarge holes in the slides,
 - b) Vary sucker bar tilt,
 - c) Equalize pile by underlaying cardboard or wooden wedges.

Troubles on the feed table and at the side lay

1. Sheet slips on to the lateral sheet smoothers. Fix smoother nearer to the centre.
2. Sheet corner slips over the cover plate of the side lay. Fix short smoother with bent-over flat spring above the side lay.
3. Front edge of sheet curls up at the outside smoothers.

Cause: The sheet is curled up, or the edge of the smoother has a dent catching the sheet.

4. Sheet jumps at the side lay:
 - a) Side edge of sheet is curled down and sticks in the cut outs at the bottom edge of the feed board. Counter-roll stock.
 - b) Sheet is curled and hits the foot of the swinging gripper. Counter-roll paper.
 - c) Sheet sticks with front corner in the counter-sunk guide-way for the side lay. This occurs chiefly with stiff stock if the paper edges curl down or if the corner is folded. Before loading the pile on the feed board straighten bent or folded corners.

Curling up or down of sheet edges is very often caused by building up the pile with small lots of paper, the edges of which lots have been left projecting from the pile to denote certain quantities of sheets. In time the sheet edges curl down or they are damaged. Therefore, it is advisable that counted amounts of sheets are marked by strips of paper and not by different piling.

Sheet is not registered correctly at the side lay — bad registering

1. Cover plate of the side lay is adjusted too high or too low.
2. Cover plate is dirty.
3. Side lay is not correctly adjusted.
4. Side standard on the feed table must be readjusted as it does not align with the side lay. This readjusting may be necessary as there is always a tendency with feed tables made of wood to warp a little by influence of atmosphere.

5. Side standards on the feed table jam because they do not stand vertical and, therefore, the sheet edges are curled up or down at the sides so that they are not correctly positioned at the side lay. This can be also be caused by warping or bending of the feed table especially if a very heavy pile is loaded. The side standards must be adjusted vertically by underlaying a little thick paper or a piece of cardboard and then the pile has to be repositioned accordingly.
6. Fixing screw of the side lay is not tightened and, therefore, the side lay jams on the feed board and operates with a jerky movement.
7. Feed board is dirty or oily so that the sheet sticks to the board and cannot be pushed correctly.
8. A smoother is too low and holds up the sheet when it should be registered.
9. Stiff and smooth stock is apt to jump at the front lays. This jumping can be eliminated by inserting the brake bands and brake brushes.

Troubles with transport of sheet on the feed board

1. Smoothers are tilted forward or backward so that the run of the sheet is hampered.
2. Smoother is positioned too far off the side edge of the sheet so that the sheet hits the foot of the swinging gripper.
3. The sheet is damaged, or jumps off the front lay, so that it cannot be taken correctly by the cylinder grippers. The cause is that the sheet becomes stuck at the feeler rods of the automatic cut-out because the dog cam is out of position. Run the job without the automatic cut-out and apply for a fitter.
4. Sheet falls too far after being released by the feedboard grippers and jumps off the front lays. The reason is that the air blast of the blower on the feed table is not correctly adjusted, or that the rear stops on the feed table are not fixed close enough to the pile, so that the sheet is blown back and caught by the sucker bar and the feed table grippers with too narrow a margin.

5. Bad register by rocking of the sheet because more than two front lays are in operation, or because the edge was not cut straight.
6. To avoid registering troubles at the front lays these must be kept absolutely clean and it also should be ensured that the surface of the feed board near the front lays is kept especially smooth and clean.
7. Front lays have to be locked after they have been adjusted.
8. Sheet does not come to the front lays because stock is too thick, too wavy, or curled at the edges.

Troubles with the transport of the sheet and registering are very often caused by wavy paper. The waves in the paper originate from unsuitable storage. If the stock is built up in very high piles and the air is too dry, the paper dries out at the edges while moisture is retained in the centre of the pile. The paper bulges in the middle and wrinkles at the edges. If the air is too moist the paper edges absorb more moisture than the centre area, with the same effect as above. If the process has not developed so far that another stock must be used, it is best to air the paper by hanging it up, later running it through the machine without impression, and then restocking in small piles. It is not advisable to equalize waves in the paper by sticking cardstrips or wedges on the packing as this will cause many other difficulties, such as bad register.

Register can be affected also by worn bristles on the cylinder brush, or by one with bristles which are too short. Bad register can be caused by a brush which is adjusted too tight to the cylinder. If the interval between the first and the second run is lengthy, the paper may be affected by varying climatic conditions. Sometimes the paper stretches during the first run and causes bad register in the second run.

Slur

1. Make-ready slipped.
2. Packing creeping.
3. Blocks adjusted too high or too low.
4. Cylinder over- or underpacked.

5. Springy forme.
6. Ink too thin.
7. Rollers not adjusted correctly.
8. Rollers not round.

The different causes of slur have already been described in the chapter "Printing in General" on pages 22—29.

Working up in the forme

1. Malformed or tapered type.
2. Mounts for blocks not square.
3. Malformed or tapered furniture.
4. Badly locked type material.
5. Bad make-up.
6. Badly locked formes.
7. Chase bent or out of shape.
8. Forme locked too tight so that it springs.
9. Cylinder overpacked.
10. Rollers adjusted too low.
11. Fragments of paper in the main pinion and the racks, causing vibration.

Bad inking

1. Oily or greasy slow-drying washing agent; ink becomes smeary.
2. Ink not suitable for the stock or for high speeds.
3. Machine is very cold so that ink is too stiff. (Heating device for ink duct see page 128.)
4. Rollers are not round, or not tacky, or the surface is damaged. Rollers are not adjusted correctly; they skid or are set too tight.
5. Roller bearing not locked.
6. Too much reciprocation.

See also chapters "Printing in General" (on page 29—30), "Treatment of Rubber Rollers" and "Treatment of Plastic Rollers" on pages 49—51.

The printed sheet shows hairline smears

1. Sheet guide rollers at the delivery, which keep the sheet to the cylinder, should be adjusted to print-free areas.
2. Star wheels should be moved from the place where they smear to a print-free area, or a place which does not smear so easily.
3. Cylinder brush set too tight.

The sheet shows broad smears

1. Set star wheels closer together so that the sheet cannot sag on to the bars.
2. If this is still not sufficient, insert sand-paper sleeves, or alter position of the bars on the chain.
3. Rubber rollers on the feeler bar of the feed should be moved to print-free spaces, or to such places that do not smear so easily.

The print is scratched on the rear side of the sheet

1. Ink or fragments of dirt accumulated on the bent top edge of the feed table. Clean the curved part. If jobs are very difficult in this respect then glue a plush strip on the curved part of the feed table.
2. Cylinder packing was not oiled when the sheet was backed up.

Troubles at the delivery

1. As the sheet on the Original Heidelberg Cylinder is guided by grippers all the way from

the feed table to the delivery pile, it is very seldom that difficulties arise during the transportation of the sheet. It is important, however, that the run of the paper through the machine is checked before the forme is adjusted so that the printer is sure that the paper is in the correct position in the grippers, especially with smaller sizes, so that the corners cannot be turned up.

2. Front edge of sheet curls up when the delivery carriage is on its way to the delivery pile.

- a) Sheet guides on the square bar, which keep the sheet to the chain delivery when it is turned, should be correctly placed,
- b) regulate air blast of the blower,
- c) air blast of the pipe directly over the delivery pile should be adjusted correctly.

Sheet is taken back by the delivery carriage

See chapters "Paper" and "Devices for Eliminating Static Electricity" (Pages 133—134 and 128).

Machine is not cut out automatically if no sheet is fed

Feeler rods for the automatic cut out on the swinging gripper are dirty so that they cannot drop. Clean the mechanism with roller washing agent or petroleum.

Alternatively, feeder rods are fouling edge of cylinder packing, which must be drawn tightly round clamp edge of cylinder with no bulges.

Instructions for eliminating troubles of the spraying apparatus

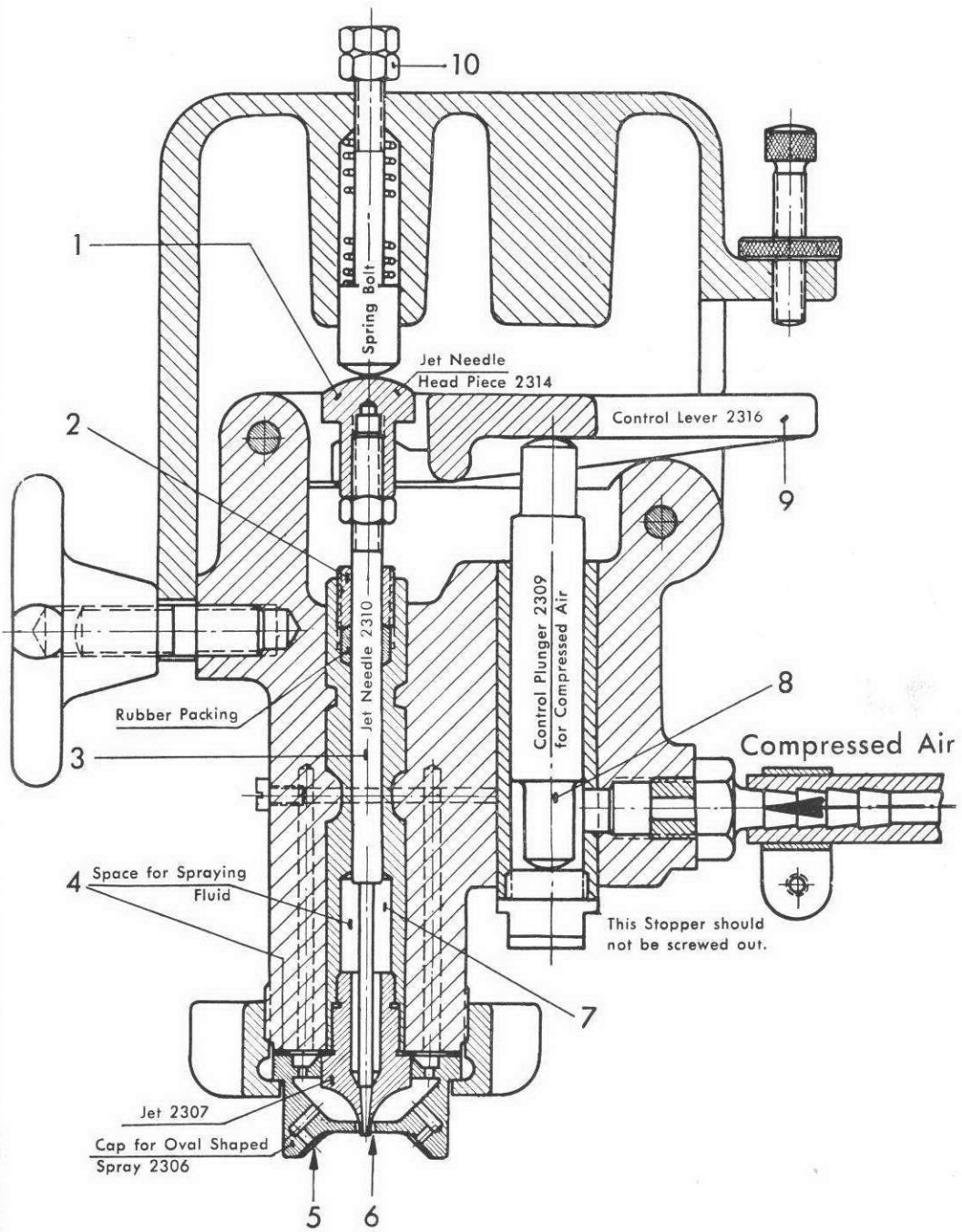

No. 1 The head piece of the jet needle is adjustable. It should **not** rest on the control lever, in order that the jet needle may seat tightly in the cone of the jet. If the head piece of the jet needle rests on the control lever the spraying fluid will not be atomized properly and drops will be formed.

No. 2 Under this threaded piece, a rubber packing is placed for the jet needle. The screw should only be turned in so far that the movement of the jet needle is not hampered. If this is not observed drops will form.

No. 3 The jet needle can never get stuck by dried up spraying fluid if it is taken out **daily** and given on **oil film**. The jet needle should be drawn out absolutely vertical and special care has to be taken that it is not damaged. Bent jet needles cause one-sided spray and have to be replaced.

No. 4 With the latest type of spraying equipment the cap is packed by a rubber ring which lies in a groove inside the cap. It need not be removed when the apparatus is cleaned. As this rubber ring is constant, the new type of spraying apparatus precludes the formation of drops.

No. 5 The small drills in the cap for spraying an oval shape are often obstructed by dried spraying fluid, even if the cap has been washed in warm water. If they are not kept open the sheet will be sprayed one-sided. The cleaning of the holes should not be done with a bodkin as the cap can be very easily damaged. It is best to use a piece of soft wire such as is used for binding flowers, because this will not scratch the brass.

No. 6 There is a small air gap of 0.2 mm between jet and cap. If dried up spraying fluid has filled the gap it must be removed with the finger.

No. 7 In this place many spraying agents deposit a thick pulp which cannot even be dissolved by flush cleaning. This pulp should be removed with a rag, after removing the jet

needle and jet. If small particles of this pulp find their way to the jet and are sprayed on to the sheet, the sheets will stick together.

No. 8 If the control plunger has been cleaned, it has to be given a coating of oil before it is re-inserted.

No. 9 The control lever should be movable for a few millimetres before it strikes the head piece of the jet needle. If this is not the case, the head piece of the jet needle has to be readjusted upwards.

No. 10 This nut should not rest on the cover. It is necessary that the full pressure of the spring is loaded on the jet needle. There should be a distance of 3 to 5 mm.

Our engineers again and again find that the jets have been screwed out with a pair of pincers instead of the suitable key and, therefore, are damaged. The jet needle and the air control plunger, also, are very often injured by using a pair of pincers for their removal. It is quite clear that these parts can no longer work properly. They cause troubles and must be replaced. Bent jet needles which may have been dropped whilst cleaning them are the cause of many troubles, therefore, it cannot be over-emphasized that all parts of the spraying apparatus have to be handled with the utmost care.

Finally, it should be observed that the cock on the air pump should be opened before the spraying apparatus is used, so that oil which has accumulated in the pump is blown off. The best way to do this is when the operator is running up the ink.

Instruction for removing trouble with the powder spraying equipment

1. Troubles with the powder sprayer are very often caused by hygroscopic powder. The powder absorbs moisture from the air and becomes lumpy so that it cannot be whirled up easily by the air blast. Such makes of powder should not be used. Wind sifted limestone powder K 4 avoids this occurrence.

2. Most of the powders which are offered on the market are not wind sifted. They are powders which contain small dust particles with a grain diameter of only some thousandth parts of a millimetre and they are built on a starch basis or of similar material. These agents are inclined to form lumps and are also unhealthy.
3. The inside of the tubes of the powder spraying apparatus have to be cleaned and the powder deposit removed, from time to time, by means of a brush which is supplied with the accessories of the machine. The jets which distribute the powder over the pile have to be unscrewed so that powder which may have filled the holes can be removed. See pages 104 and 105.
4. If the adjustment control for the quantity of powder to the various tubes does not work properly, the complete lid has to be lifted off the powder container – after loosening the hexagon nut in the centre. The powder deposit can then be removed from the channels to the various tubes. As this is being done, the opportunity should be taken to clean the inside of the tubes as mentioned in paragraph 3.

**ORIGINAL HEIDELBERGER CYLINDER 22¹/₂x32¹/₄" (57x82 cm)
CUTTER AND CREASER**

Frequently printers or paper processing plants must perform such jobs as perforating, cutting, slitting, creasing, die-cutting or embossing after printing is completed. To produce these jobs efficiently, special machinery is generally required and is usually found only in large shops or converting plants.

Printers will also receive many orders for the printing of packaging items such as folding boxes. In the past, the printing portion of such jobs was done by small or medium-sized shops, whereas the cutting, creasing, die-cutting and embossing was left to larger firms or plants having special machinery for these operations.

To enable the printer to have a more versatile and more profitable overall operation, we are placing the Original Heidelberg Cylinder on the market in a cutter and creaser model. Our decision to produce a cutter and creaser came after a number of plants began to ask for additional machines for exclusive use on nonprinting operations.

Although it is only a comparatively short time since the Original Heidelberg Cylinder Cutter and

Creaser was introduced, the machine has been well received and is growing in quantity in the printing and paper and board converting industries.

The Cutter and Creaser is quite rugged. It has a heavy, onepiece base casting with 6-point support, four precision ground bed tracks and a heavy precision ground bed. This unit will accommodate both .937" and .918" dies. Bed plates for .937" and .918" rule permit underlay to be easily placed under the form. The Cutter and Creaser has essentially the same principle and features as the printing press with the exception that it has been adapted to converting operations.

In front of the cylinder, a heavy bar is mounted upon which perforating, slitting and scoring heads can be attached. By using scoring blades, perforators or cutting wheels a sheet can be cut, perforated or scored in one process.

The impression cylinder is readily accessible because there is no inking apparatus. The form is protected by a safety guard. The machine cannot start if the guard is swung up (see illustration 153).

Illus. 153

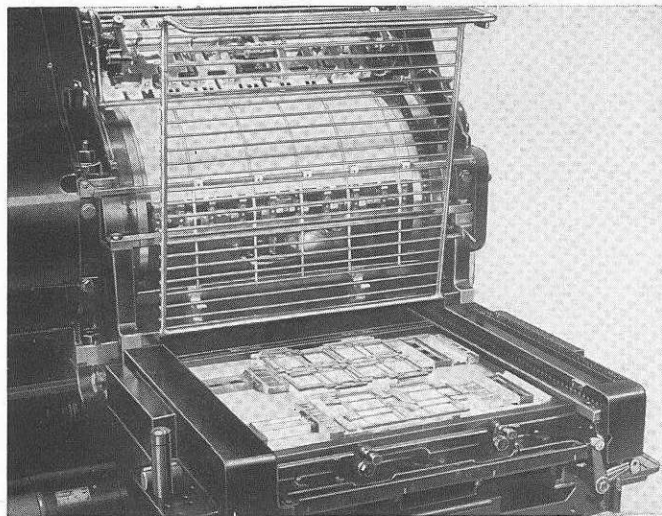

Operation of the Cutter and Creaser is the same as the Original Heidelberg Cylinder printing press. Therefore, essentially all instructions given in this book will also apply to the Cutter and Creaser.

For regularly long runs of heavy card a special pre-loading device is available which can be operated while the machine is running.

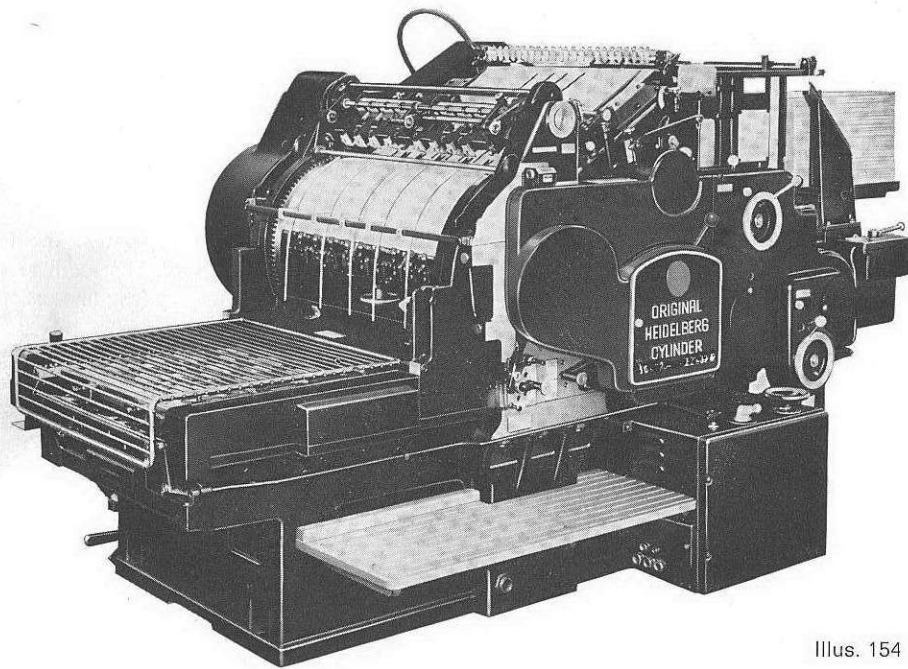

Illus. 154

The illustration 155 shows pre-loading directly over the delivery pile. At the front of the pre-loading board the bars, in combination with the side standards, allow the stock to be piled whilst the machine is running. As soon as the pile is low enough for a new pile to be placed in position, the bars of the front are swung away, and the new pile

is positioned beneath the board bearing the remainder of the existing pile. After the last sheet on the upper feed board has been fed and the machine stopped, the rear sheet stops are swung away and the angled handles of the locking bars on both sides are turned by 180° to release the board. On the device, consisting of two sloping rails the

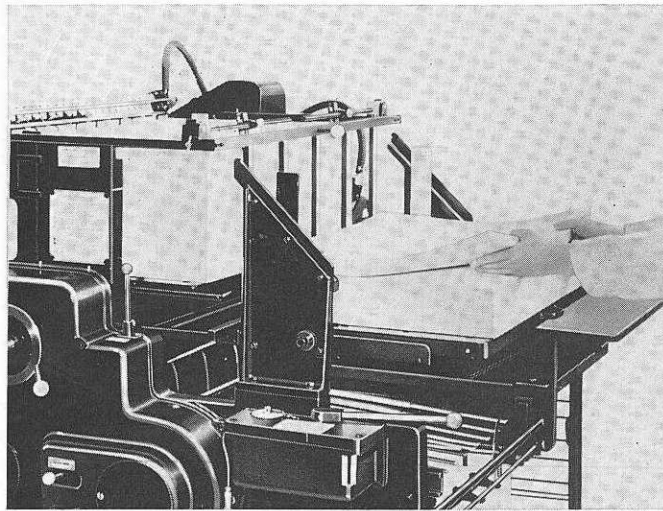

Illus. 155

board has now to be pulled backward and tilted on the sloping rails. It then slides automatically to the pre-loading position but must be guided by hand, using the handle on the board. As soon as the board has reached its position in the pre-load-

ing device, the transporting bar together with the board locking device is lowered by means of the handwheel till it descends beneath the spare feed table. Then the board is relocked and the new pile lifted to its correct position.

To the machine minder operating the Original Heidelberg Cylinder
22½ x 30¼ / 22½ x 32¼"

The Original Heidelberg Cylinder was designed and manufactured to conform with the practical demands of letterpress printers. We feel certain that we have fulfilled their needs for a modern, productive and profitable machine. We hope that this manual will not only ensure proper maintenance of the press but will also give you a better insight into progressive printing methods. Should you have any suggestions which you feel are of importance or practical value for daily operation of the machine, please do not hesitate to contact your Heidelberg representative.

We extend our best wishes for your happy and successful operation of the Original Heidelberg Cylinder.

**HEIDELBERGER DRUCKMASCHINEN
AKTIENGESELLSCHAFT**

THE HEIDELBERG MANUFACTURING PROGRAMME

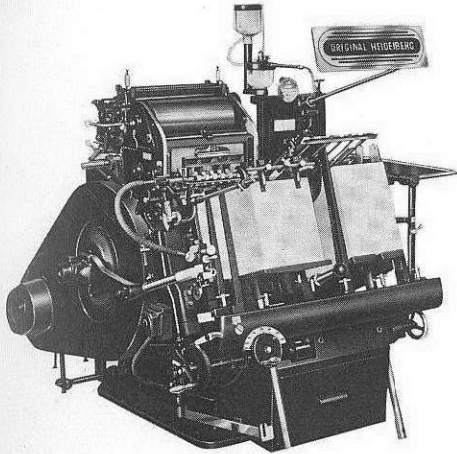

10 x 15" and 13 x 18" Original Heidelberg Automatic Platens

Model	Max. Size	Max. Speed
T	10 x 15"	5.500
GT	13 x 18"	4.000
GTK	13 x 18"	4.000

13 x 18" Heidelberg Special Cutter + Creaser for Gold and Colour Roll Foils and Hot Embossing

Model	Max. Size	Max. Speed
GTP	13 x 18"	4.000

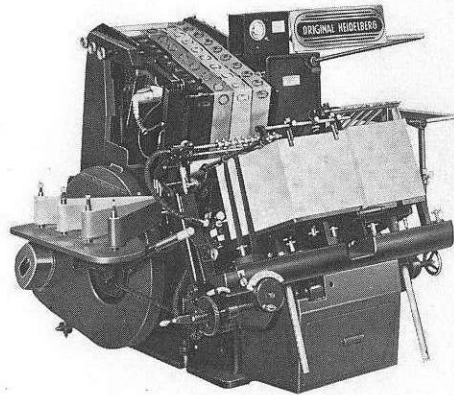

13 x 18" Heidelberg Automatic Platen Cutter + Creaser

Model	Max. Size	Max. Speed
GTS	13 x 18"	4.000

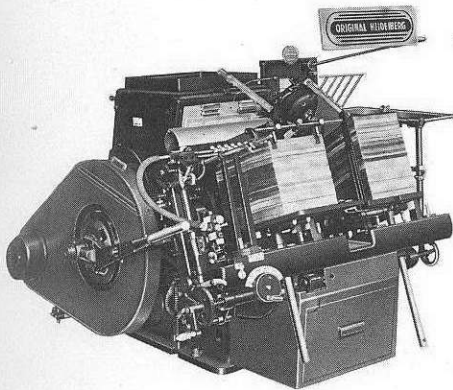

**15 $\frac{3}{4}$ x 23", 18 x 23", 22 $\frac{1}{2}$ x 30 $\frac{1}{4}$ " 22 $\frac{1}{2}$ x 32 $\frac{1}{4}$ " and
25 $\frac{1}{4}$ x 35" Original Heidelberg
Automatic Cylinder Presses**

Model	Max. Size	Max. Speed
KSB	15 $\frac{3}{4}$ x 23"	5.000
KSBA	18 x 23"	5.000
SBG	22 $\frac{1}{2}$ x 30 $\frac{1}{4}$ "	4.600
SBB	22 $\frac{1}{2}$ x 32 $\frac{1}{4}$ "	4.600
SBD	25 $\frac{1}{4}$ x 35"	4.000

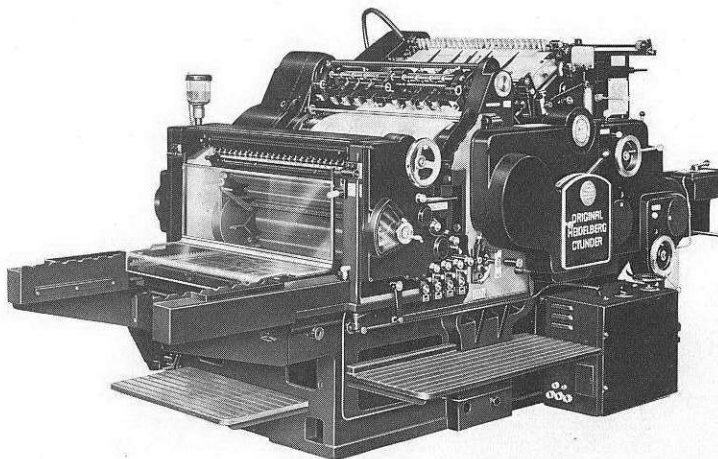

**15 $\frac{3}{4}$ x 23", 18 x 23", 22 $\frac{1}{2}$ x 30 $\frac{1}{4}$ ", 22 $\frac{1}{2}$ x 32 $\frac{1}{4}$ " and
25 $\frac{1}{4}$ x 35" Heidelberg Two-colour Rotary
+ Flat Cylinders**

Model	Max. Size	Max. Speed
KSBZ	15 $\frac{3}{4}$ x 23"	5.000
KSBAZ	18 x 23"	5.000
SBGZ	22 $\frac{1}{2}$ x 30 $\frac{1}{4}$ "	4.600
SBBZ	22 $\frac{1}{2}$ x 32 $\frac{1}{4}$ "	4.600
SBDZ	25 $\frac{1}{4}$ x 35"	4.000

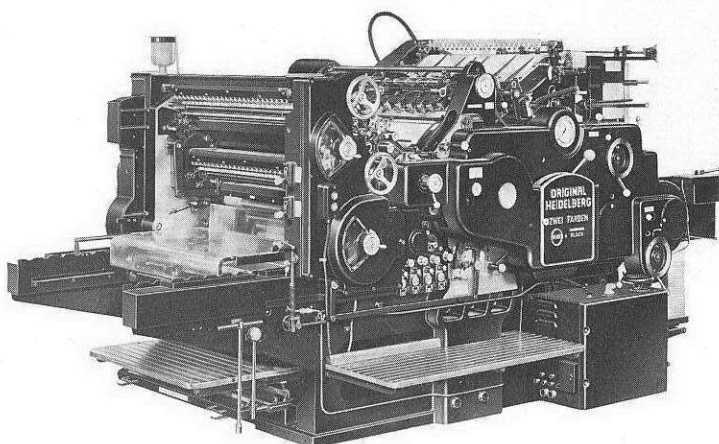

22 $\frac{1}{2}$ x 32 $\frac{1}{4}$ " Heidelberg Cylinder Cutter + Creaser

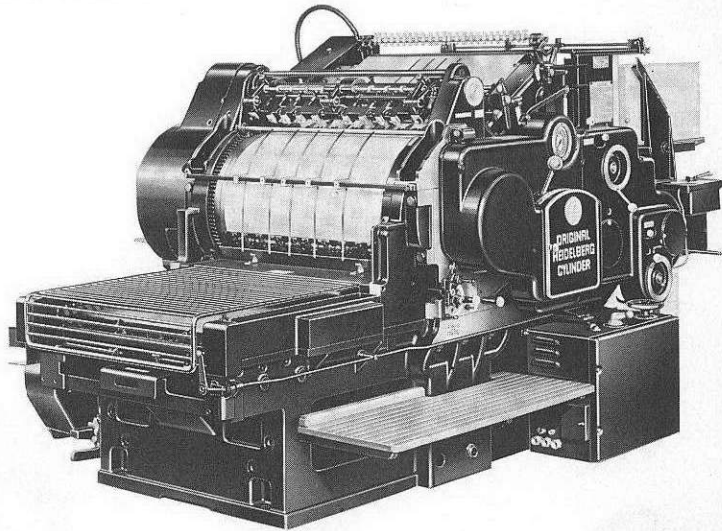

Model	Max. Size	Max. Speed
SBBS	22 $\frac{1}{2}$ x 32 $\frac{1}{4}$ "	4.600

15 $\frac{3}{4}$ x 22 $\frac{1}{2}$ ", 18 x 22 $\frac{1}{2}$ " 18 x 25 $\frac{1}{4}$ " and 20 $\frac{1}{2}$ x 28 $\frac{3}{8}$ " Heidelberg Single-colour Sheet-fed Rotaries for Offset or Letterset

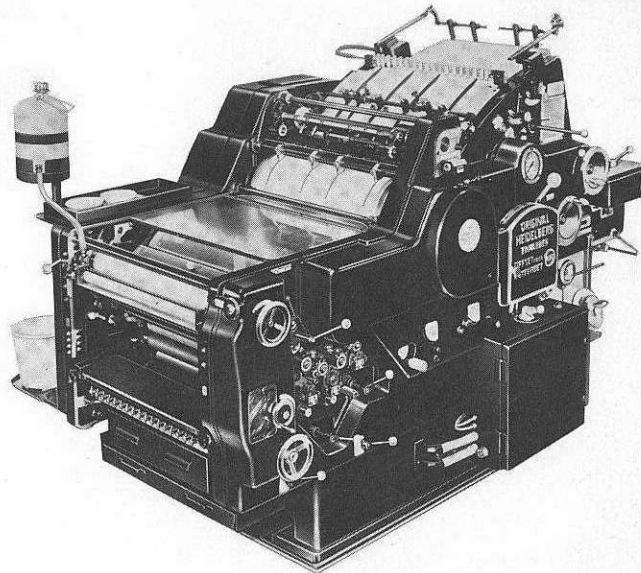

Model	Max. Size	Max. Speed
KOR	15 $\frac{3}{4}$ x 22 $\frac{1}{2}$ "	5.500
KORA	18 x 22 $\frac{1}{2}$ "	5.500
KORD	18 x 25 $\frac{1}{4}$ "	5.500
KORS	20 $\frac{1}{2}$ x 28 $\frac{3}{8}$ "	5.500

24 x 32 $\frac{1}{4}$ " and 25 $\frac{1}{4}$ x 35" Heidelberg Single-colour Sheet-fed Rotaries for Offset and Letterset

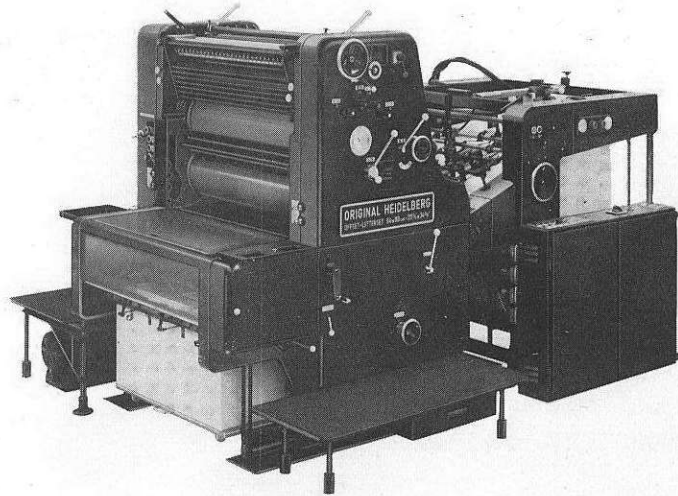

Model	Max. Size	Max. Speed
SOR	24 x 32 $\frac{1}{4}$ "	8.000
SORD	25 x 35"	8.000

15 $\frac{3}{4}$ x 22 $\frac{1}{2}$ " Two-colour Sheet-fed Rotary Letterpress

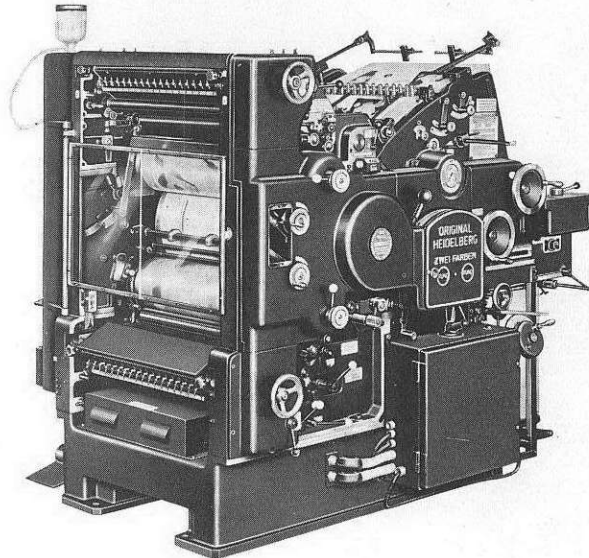

Model	Max. Size	Max. Speed
KRZ	15 $\frac{3}{4}$ x 22 $\frac{1}{2}$ "	5.500

25¼ x 35" Heidelberg Rotary Single-colour Letterpress

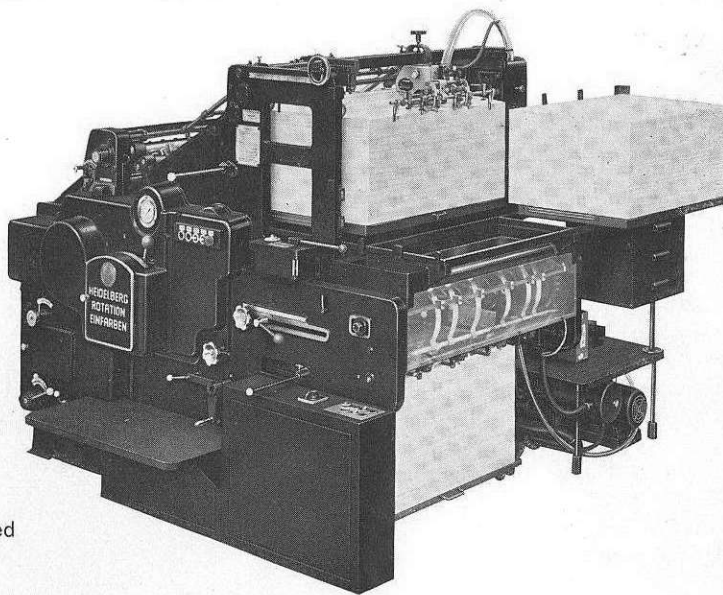

Model	Max. Size	Max. Speed
SRDE	25¼ x 35"	5.500

25¼ x 35" Heidelberg Rotary Two-colour Letterpress

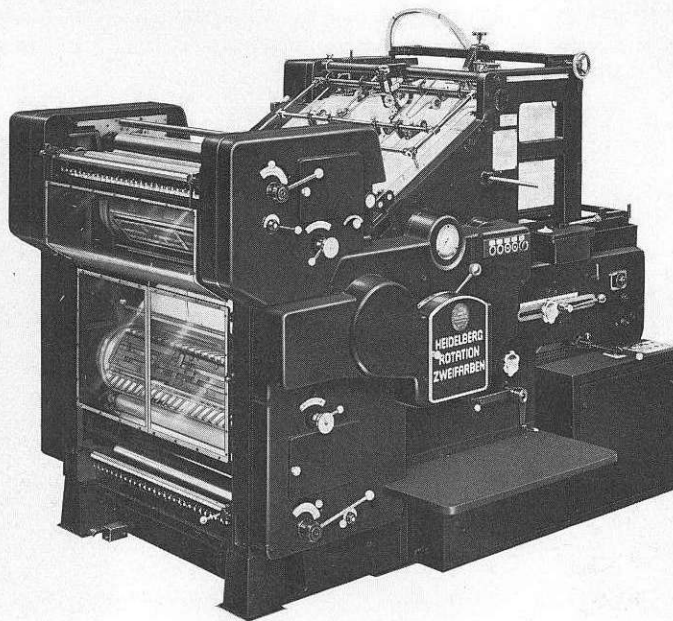

Model	Max. Size	Max. Speed
SRDZ	25¼ x 35"	5.500

25¼ x 35" Heidelberg Rotary Letterpress Perfector

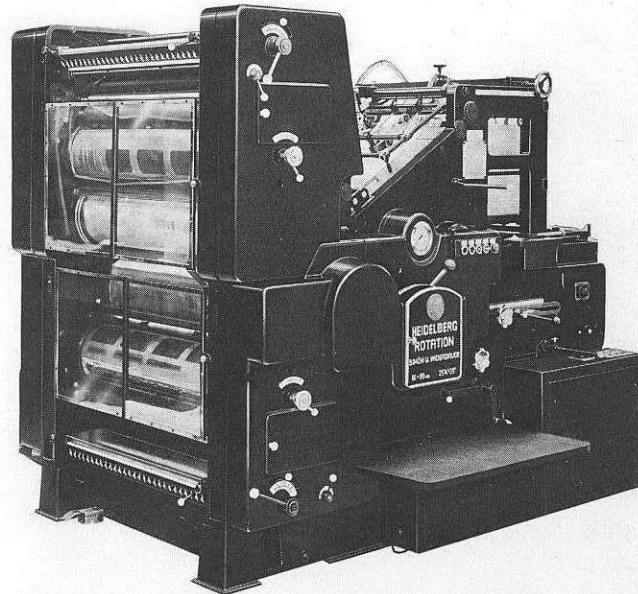

Model	Max. Size	Max. Speed
SRDW	25¼ x 35"	5.500

REN 28 x 40" Heidelberg Rotaspeed Letterpress Single-colour Standard Pile — Max. Speed 8.000

RON 28 x 40" Heidelberg Rotaspeed Offset Single-colour Standard Pile, — Max. Speed 8.000
or in Combination with Letterset

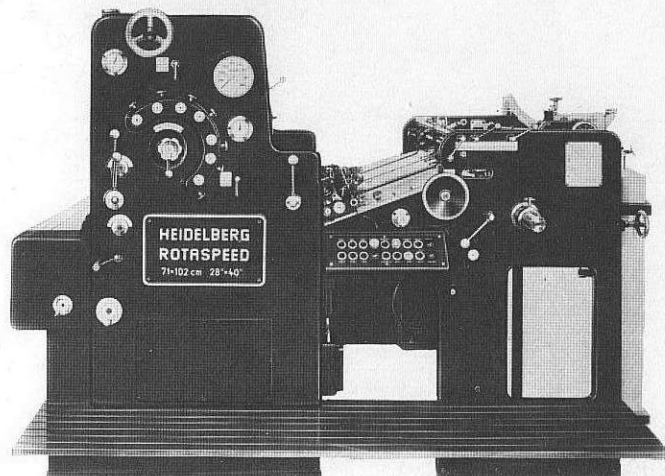

REH 28 x 40" Heidelberg Rotaspeed Letterpress Single-colour High Pile — Max. Speed 8.000
ROH 28 x 40" Heidelberg Rotaspeed Offset Single-colour High Pile, — Max. Speed 8.000
or in Combination with Letterset

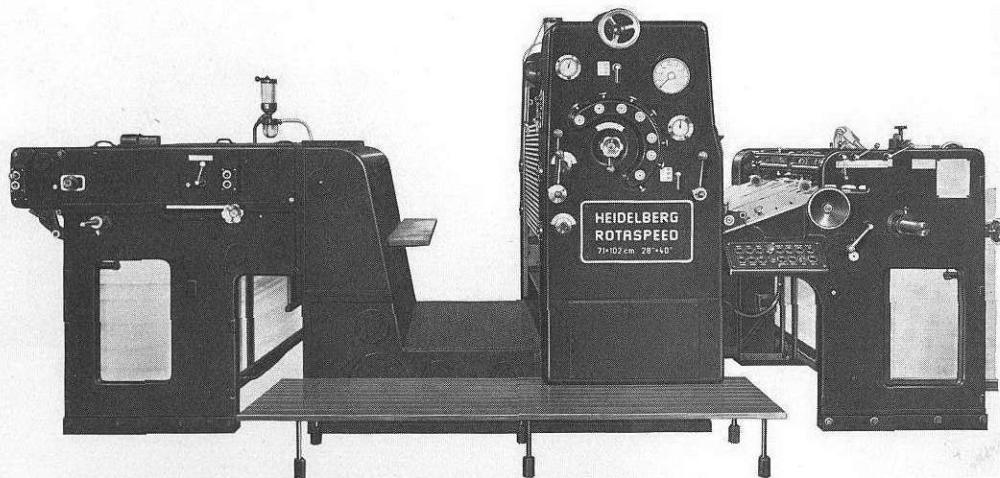

RZB 28 x 40" Heidelberg Rotaspeed Letterpress Two-colour — Max. Speed 7.000
RZO 28 x 40" Heidelberg Rotaspeed Offset Two-colour, — Max. Speed 7.000
or in Combination with Letterset

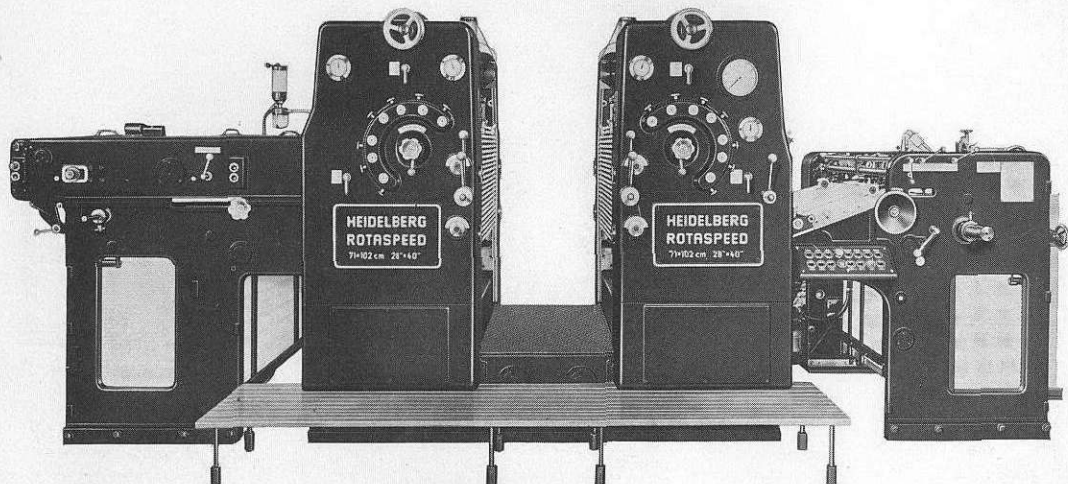

RVB 28 x 40" Heidelberg Rotaspeed Letterpress Four-colour — Max. Speed 7.000
RVO 28 x 40 Heidelberg Rotaspeed Offset-Four-colour, — Max. Speed 7.000
or in Combination with Letterset

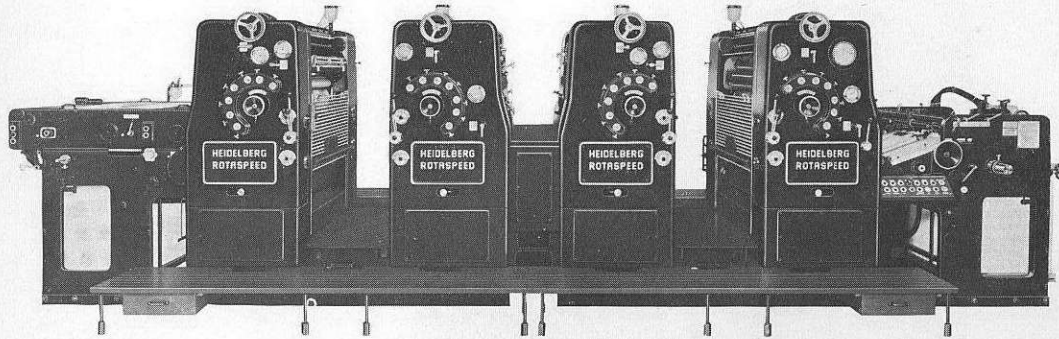

RZOB Three-colour, RVOB Five-colour, RVOBB Six-colour — Max. Speed 7.000
28 x 40" Heidelberg Rotaspeed Combi-Sheet-Fed Rotary

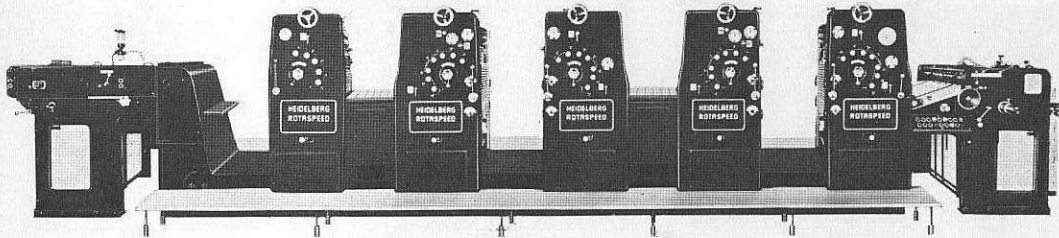

Printed in Western Germany 1967. Reproduction of any contents is permissible only if source is stated.

Contents printed on Original Heidelberg Cylinder. Gold embossing of the cover executed on Heidelberg Special Cutter and Creaser for Hot Stamping of Gold and Colour Roll Foils.

Essential parts, devices and attachments of the machine are protected by domestic and foreign patents as well as trade marks. The names **Heidelberg** and **Original Heidelberg** have been registered both in Germany and abroad.

Essential parts of the Original Heidelberg Cylinder, as far as patented units, devices and attachments are concerned, may only be repaired, changed or installed by the factory or our authorized representatives.



HEIDELBERGER DRUCKMASCHINEN
AKTIENGESELLSCHAFT